

PARTS CATALOGUE

YZ85'05 (5PAA) SOUTH AFRICA

YZ85LW'05 (5SHA) SOUTH AFRICA



1D5PA-100E1

(2D5PA-100E1)

YZ85T
YZ85/YZ85LW
PARTS CATALOGUE
©2004 by Yamaha Motor Co., Ltd.
1st edition, May 2004
All rights reserved.
Any reprinting or unauthorized use
without the written permission of
Yamaha Motor Co., Ltd.
is expressly prohibited.
Printed in Japan.

A3



A4

FOREWORD

This Parts Catalogue is related to the parts for the model(s) on the cover page. When you are ordering replacement parts, please refer to this Parts Catalogue and quote both part numbers and part names correctly.

1. Modifications or additions which have been made after the issue of the Parts Catalogue will be announced in the Parts News.

It is advisable that you make the necessary corrections to the Parts Catalogue according to the Parts News.

2. Abbreviations

The following abbreviations are used in this Parts Catalogue.

“UR” Use specified parts number.

“UN” Use as many as needed.

“AP” Alternate Parts

“LM” Locally Made (Parts need to be ordered locally)

“F#” Frame No. (Applicable machine No.)

“O/S” Over Size

3. The number of components for assembly

- Parts, which are to be supplied in an assembly, are listed with a dot (.) in front of the part name as shown below.
- The numeral appearing to the right of each component part indicates the quantity of parts for each assembly unit.

PART NO.	DESCRIPTION	Q'TY	REMARKS
2F5-83310-60	FRONT FLASHER LIGHT ASSY	2	
115-83311-60	.BULB (6V-18W)	1	

4. Applicable colours of graphics are represented in the “REMARKS” as shown below.

PART NO.	DESCRIPTION	Q'TY	REMARKS
2N4-24110-00-X5	FUEL TANK COMP.	2	MXR
3J1-24240-10	.GRAPHIC, FUEL TANK	1	FOR MXR

5. Note that the illustrations for reference in finding parts numbers are not to be used for assembling. When assembling, please use the applicable service manual.

6. The asterisk (*) before a reference number indicates modified items after the first edition.

FOREWORD

7. Applicable Serial No.

Engine Serial No.

Frame Serial No.

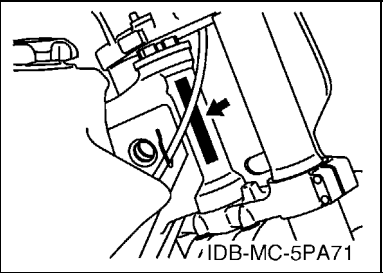
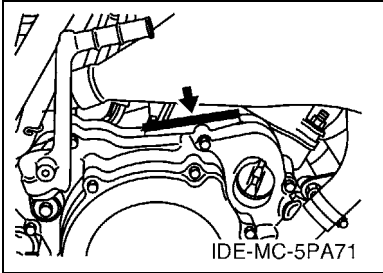

8. Applicable Colour Code (The (*) mark shows Model colour.)

Abbreviation	Colour Name	Colour Code
DPBMC	DEEP PURPLISH BLUE METALLIC C	0564
DPBSE(*)	DEEP PURPLISH BLUE SOLID E	0583

CONTENTS

ENGINE

CYLINDER	B2
CRANKSHAFT & PISTON	B3
WATER PUMP	B4
RADIATOR & HOSE	B5
INTAKE	B6
CARBURETOR	B7
EXHAUST	B9
CRANKCASE	B10
CRANKCASE COVER 1	B11
STARTER	B12
CLUTCH	B13
TRANSMISSION	B14
SHIFT CAM & FORK	C2
SHIFT SHAFT	C3

CHASSIS

FRAME	C4
FENDER	C5
SIDE COVER	C6
REAR ARM	C7
REAR SUSPENSION	C9
STEERING	C11
FRONT FORK	C12
FUEL TANK	C15
SEAT	D2
FRONT WHEEL	D3
FRONT BRAKE CALIPER	D4
REAR WHEEL	D5
REAR BRAKE CALIPER	D7
STEERING HANDLE & CABLE	D8
FRONT MASTER CYLINDER	D9
STAND & FOOTREST	D10
REAR MASTER CYLINDER	D11
GENERATOR	D12
HANDLE SWITCH & LEVER	D13
ELECTRICAL 1	D14
ALTERNATE FOR CHASSIS	D15

INDEX

NUMERICAL INDEX	M1
-----------------------	----

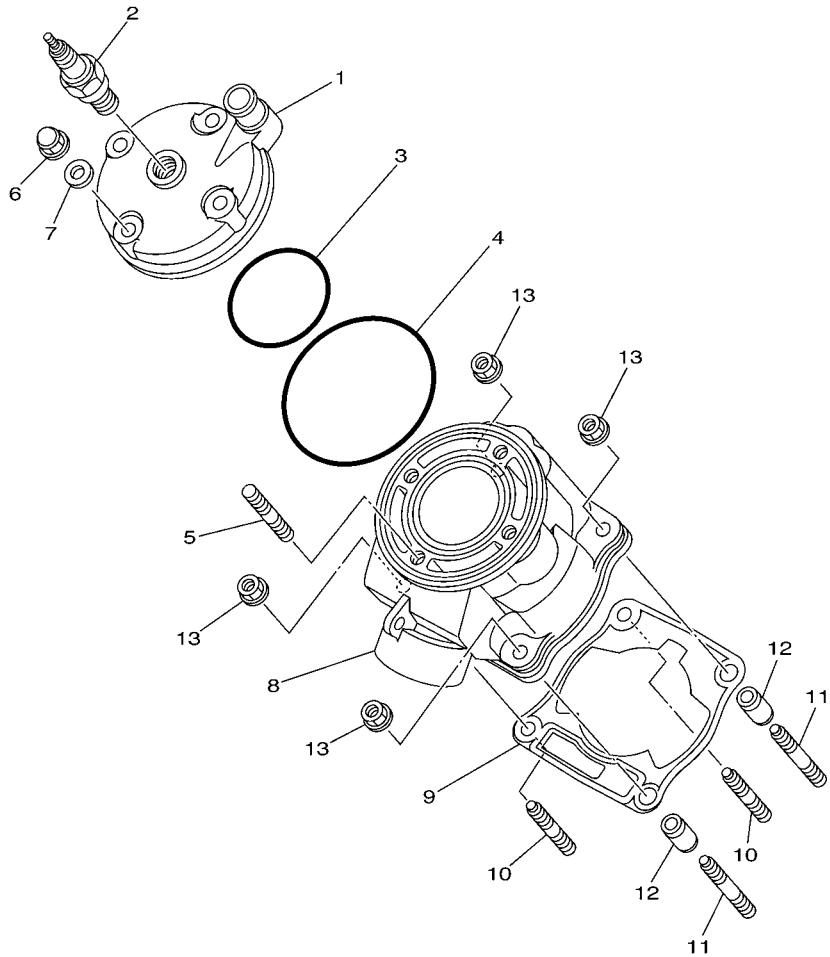

5PA1100-A010

FIG. 1 CYLINDER

REF. NO.	PART NO.	DESCRIPTION	5PAA	5PAC	5SHA	5SHC	REMARKS
1	5PA-11111-00	HEAD, CYLINDER 1	1	1	1	1	
2	NGK-BR10EG-PK4	PLUG, SPARK (NGK BR10EG)	1	1			
3	93210-56459	O-RING	1	1	1	1	
4	93210-84724	O-RING	1	1	1	1	
5	90116-08394	BOLT, STUD	4	4	4	4	
6	90176-08026	NUT, CROWN	4	4	4	4	
7	90201-080L8	WASHER, PLATE	4	4	4	4	
8	5PA-11311-00	CYLINDER 1	1	1	1	1	
9	4ES-11351-00	GASKET, CYLINDER	1	1	1	1	
10	90116-08318	BOLT, STUD	2	2	2	2	
11	90116-08388	BOLT, STUD	2	2	2	2	
12	99590-10114	PIN, DOWEL	2	2	2	2	
13	90179-08299	NUT	4	4	4	4	

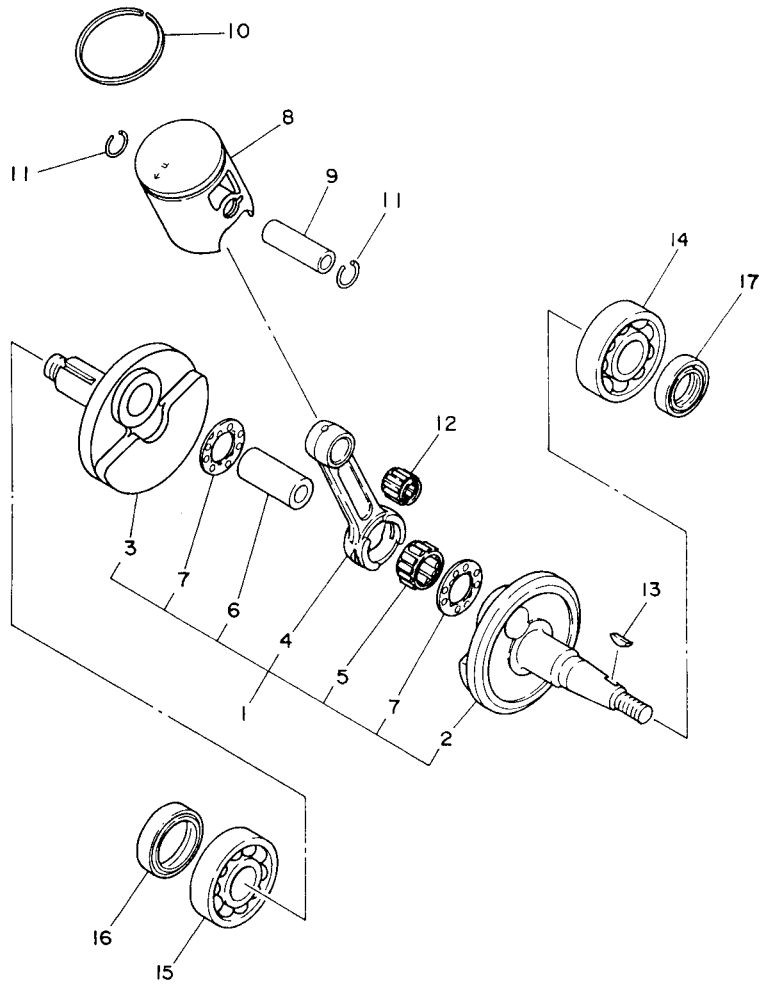

4ES1100-3020

FIG. 2 CRANKSHAFT & PISTON

REF. NO.	PART NO.	DESCRIPTION	5PAA	5PAC	5SHA	5SHC	REMARKS
1	5PA-11400-00	CRANKSHAFT ASSY	1	1	1	1	
2	5PA-11412-00	.CRANK 1	1	1	1	1	
3	5PA-11422-00	.CRANK 2	1	1	1	1	
4	4ES-11651-10	.ROD, CONNECTING	1	1	1	1	
5	93310-420B1	.BEARING	1	1	1	1	
6	2RA-11681-00	.PIN, CRANK 1	1	1	1	1	
7	90209-20159	.WASHER	2	2	2	2	
8	5PA-11631-00-A0	PISTON (STD)	1	1	1	1	UR RED
	5PA-11631-00-B0	PISTON (STD)	1	1	1	1	UR ORANGE
	5PA-11631-00-C0	PISTON (STD)	1	1	1	1	UR GREEN
	5PA-11631-00-D0	PISTON (STD)	1	1	1	1	UR PURPLE
9	4ES-11633-00	PIN, PISTON	1	1	1	1	
10	5PA-11611-00	RING, PISTON	1	1	1	1	
11	93450-16115	CIRCLIP	2	2	2	2	
12	93310-21417	BEARING	1	1	1	1	
13	90280-03017	KEY, WOODRUFF	1	1	1	1	
14	93306-20438	BEARING	1	1	1	1	
15	93306-30421	BEARING (B6304C3)	1	1	1	1	
16	93102-28009	OIL SEAL	1	1	1	1	
17	93102-20447	OIL SEAL	1	1	1	1	

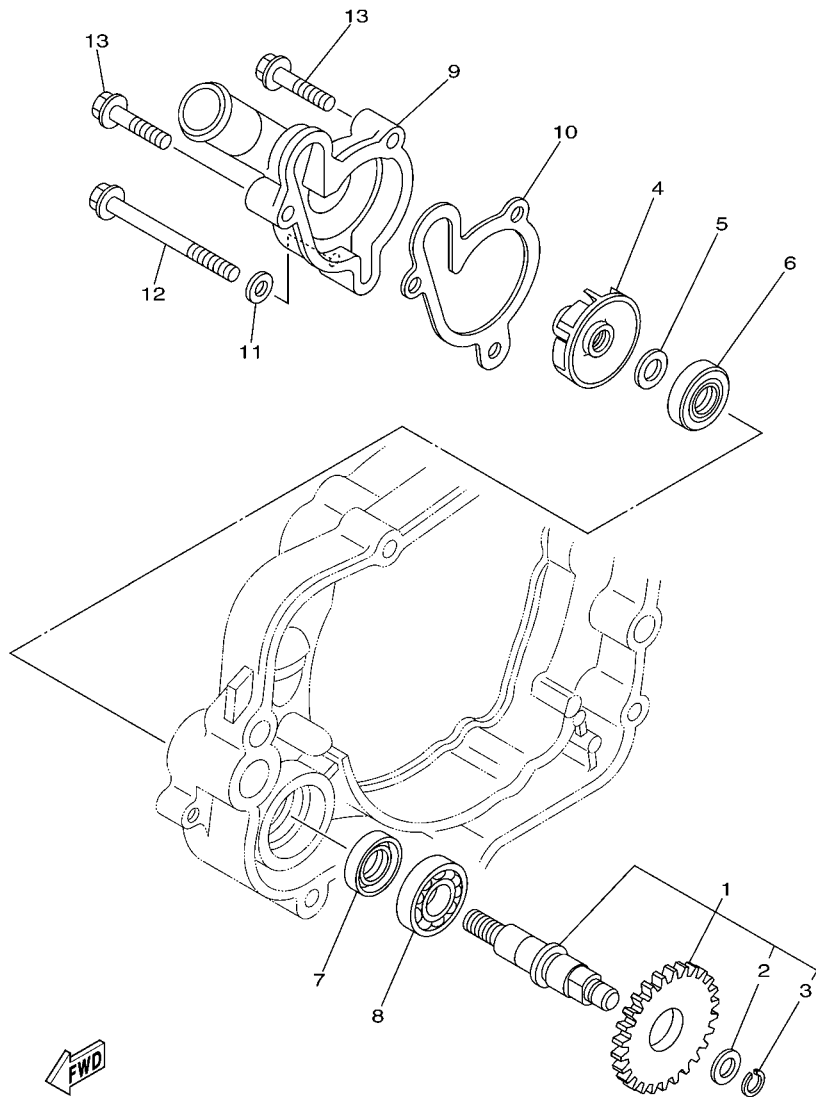

5PA1100-A030

FIG. 3 WATER PUMP

REF. NO.	PART NO.	DESCRIPTION	5PAA	5PAC	5SHA	5SHC	REMARKS
1	5PA-12459-00	GEAR, IMPELLER SHAFT	1	1	1	1	
2	90201-08512	.WASHER, PLATE	1	1	1	1	
3	93440-07182	.CIRCLIP	1	1	1	1	
4	5PA-12451-00	IMPELLER, WATER PUMP	1	1	1	1	
5	90201-08512	WASHER, PLATE	1	1	1	1	
6	93109-11073	OIL SEAL	1	1	1	1	
7	93102-12106	OIL SEAL (SD 12-22-5 HS)	1	1	1	1	
8	93306-00105	BEARING (B6001)	1	1	1	1	
9	4BA-12422-00	COVER, HOUSING	1	1	1	1	
10	4BA-12428-00	GASKET, HOUSING COVER 2	1	1	1	1	
11	90430-06166	GASKET	1	1	1	1	
12	95827-06060	BOLT, FLANGE	1	1	1	1	
13	95027-06025	BOLT, FLANGE	2	2	2	2	

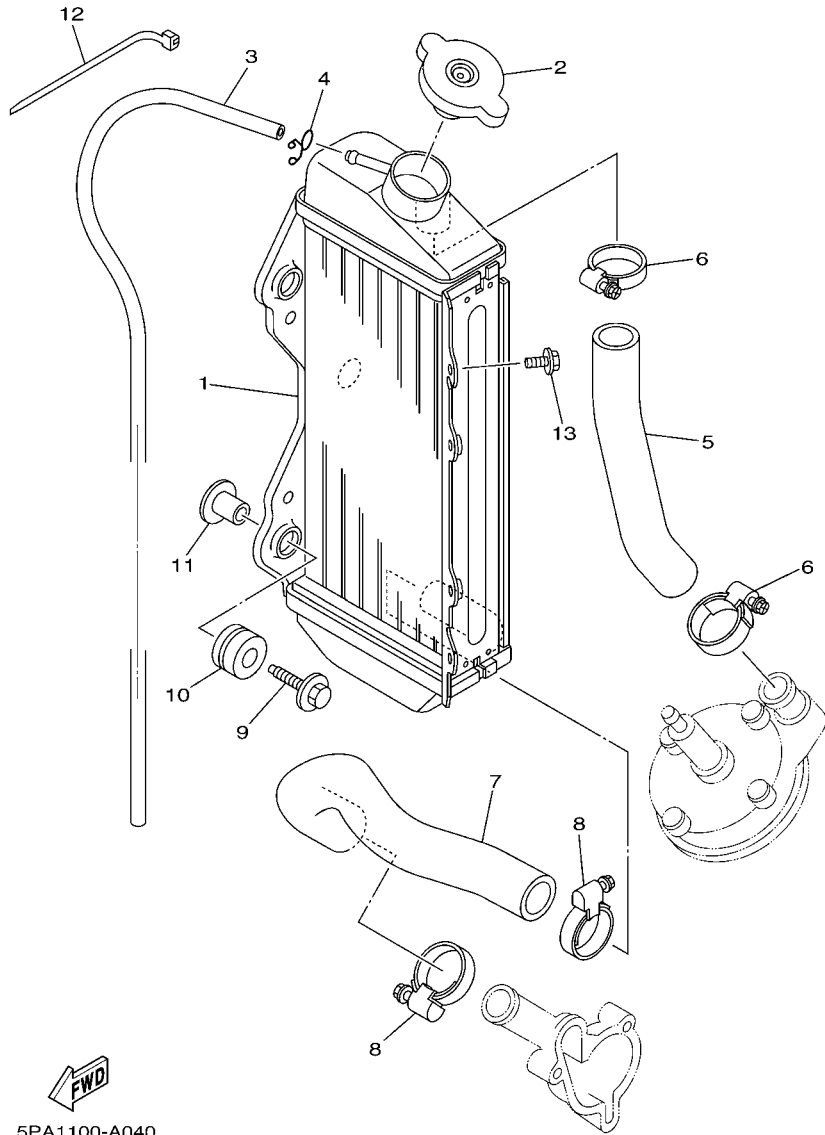

5PA1100-A040

FIG. 4 RADIATOR & HOSE

REF. NO.	PART NO.	DESCRIPTION	5PAA	5PAC	5SHA	5SHC	REMARKS
1	5PA-12461-00	RADIATOR ASSY	1	1	1	1	
2	5HD-12462-00	CAP, RADIATOR	1	1	1	1	
3	22W-12463-00	PIPE, BREATHER	1	1	1	1	
4	90467-08002	CLIP	1	1	1	1	
5	4ES-12481-10	PIPE 1	1	1	1	1	
6	90450-25037	HOSE CLAMP ASSY	2	2	2	2	
7	5PA-12482-00	PIPE 2	1	1	1	1	
8	90450-28014	HOSE CLAMP ASSY	2	2	2	2	
9	90119-06038	BOLT, WITH WASHER	3	3	3	3	
10	90480-15528	GROMMET	3	3	3	3	
11	90387-0614M	COLLAR	3	3	3	3	
12	90464-13077	CLAMP	2	2	2	2	
13	95827-06010	BOLT, FLANGE	1	1	1	1	

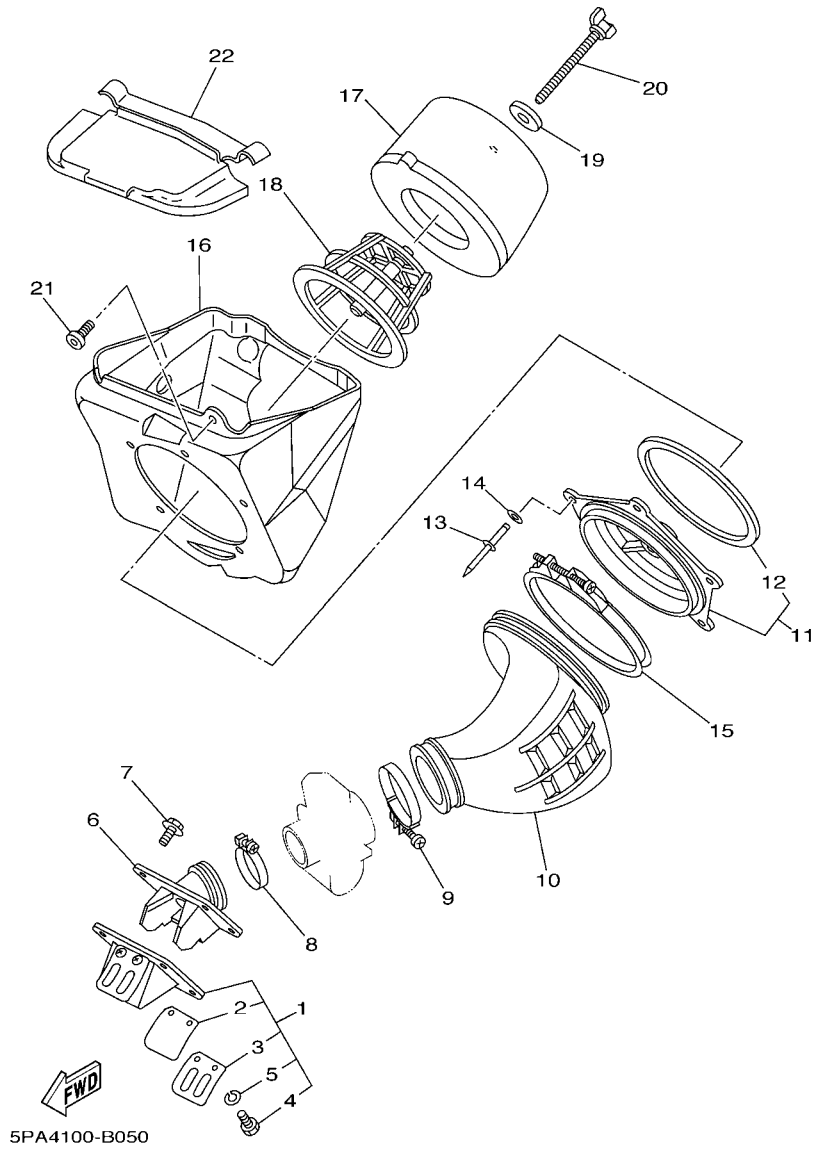
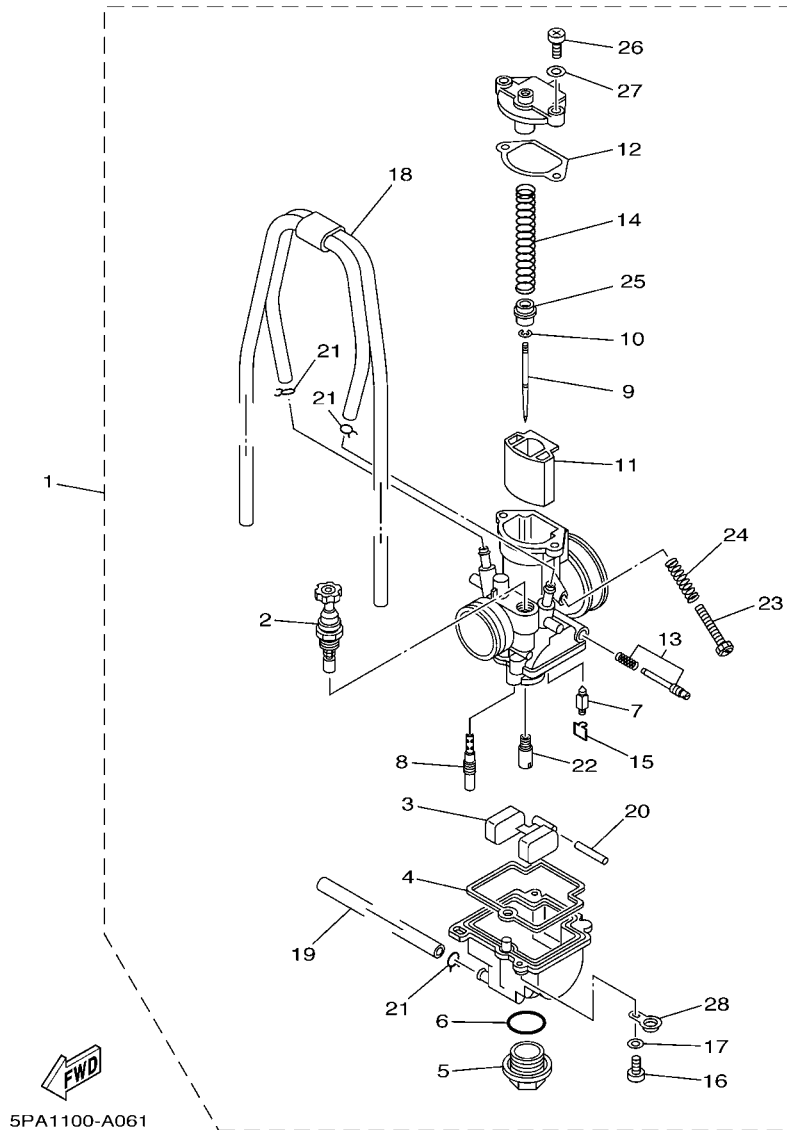

FIG. 5 INTAKE

REF. NO.	PART NO.	DESCRIPTION	5PAA	5PAC	5SHA	5SHC	REMARKS
1	4ES-13610-00	REED VALVE ASSY	1	1	1	1	
2	4ES-13613-00	.REED, VALVE	2	2	2	2	
3	4ES-13616-00	.STOPPER, REED VALVE	2	2	2	2	
4	98507-03008	.SCREW, PAN HEAD	4	4	4	4	
5	92907-03100	.WASHER, SPRING	4	4	4	4	
6	5PA-13565-00	JOINT, CARBURETOR	1	1	1	1	
7	95027-06020	BOLT, FLANGE	4	4	4	4	
8	90460-41191	CLAMP, HOSE	1	1	1	1	
9	90460-56105	CLAMP, HOSE	1	1	1	1	
10	5PA-14453-00	JOINT, AIR CLEANER 1	1	1	1	1	
11	5PA-14459-00	HOLDER, GUIDE	1	1	1	1	
12	4ES-14462-00	.SEAL	1	1	1	1	
13	90267-48138	RIVET, BLIND	5	5	5	5	
14	90201-043H7	WASHER, PLATE	5	5	5	5	
15	90450-99064	HOSE CLAMP ASSY	1	1	1	1	
16	5PA-14411-00	CASE, AIR CLEANER 1	1	1	1	1	
17	5PA-14451-00	ELEMENT, AIR CLEANER	1	1	1	1	
18	5PA-14458-00	GUIDE	1	1	1	1	
19	90209-06096	WASHER	1	1	1	1	
20	90122-06002	BOLT, WING	1	1	1	1	
21	90109-065F3	BOLT	1	1	1	1	
22	5PA-14417-00	COVER 1	1	1	1	1	AP

FIG. 6 CARBURETOR



5PA1100-A061

REF. NO.	PART NO.	DESCRIPTION	5PAA	5PAC	5SHA	5SHC	REMARKS
1	5PA-14101-00	CARBURETOR ASSY 1	1	1	1	1	
2	4JT-14171-00	.PLUNGER, STARTER	1	1	1	1	
3	5PA-14985-00	.FLOAT	1	1	1	1	
4	5PA-14984-00	.GASKET, FLOAT CHAMBER	1	1	1	1	
5	4MX-14115-00	.PLUG, SCREW	1	1	1	1	
6	4MX-14561-00	.O-RING	1	1	1	1	
7	5PA-14392-00	.VALVE, NEEDLE	1	1	1	1	
8	4MX-14948-05	.JET, SLOW (#45)	1	1	1	1	STD
	4MX-14948-04	.JET, SLOW (#42)	1	1	1	1	AP
	4MX-14948-06	.JET, SLOW (#48)	1	1	1	1	AP
9	5PA-14916-KF	.NEEDLE (NBKF)	1	1	1	1	STD
	5PA-14916-LE	.NEEDLE (NBLE)	1	1	1	1	AP
	5PA-14916-LF	.NEEDLE (NBLF)	1	1	1	1	AP
	5PA-14916-LG	.NEEDLE (NBLG)	1	1	1	1	AP
	5PA-14916-KE	.NEEDLE (NBKE)	1	1	1	1	AP
	5PA-14916-KG	.NEEDLE (NBKG)	1	1	1	1	AP
10	4MX-14919-00	.CLIP	1	1	1	1	
11	5PA-14340-00	.VALVE ASSY	1	1	1	1	
12	5PA-14126-00	.GASKET	1	1	1	1	
13	5PA-14105-00	.PILOT SCREW SET	1	1	1	1	
14	5PA-14131-00	.SPRING, THROTTLE VALVE	1	1	1	1	
15	5PA-14159-00	.CLIP	1	1	1	1	
16	98504-04014	.SCREW, PAN HEAD	2	2	2	2	
17	92903-04600	.WASHER	2	2	2	2	
18	5PA-1410E-00	.HOSE	1	1	1	1	
19	4XL-14197-10	.PIPE	1	1	1	1	
20	676-14548-00	.PIN, FLOAT ARM	1	1	1	1	

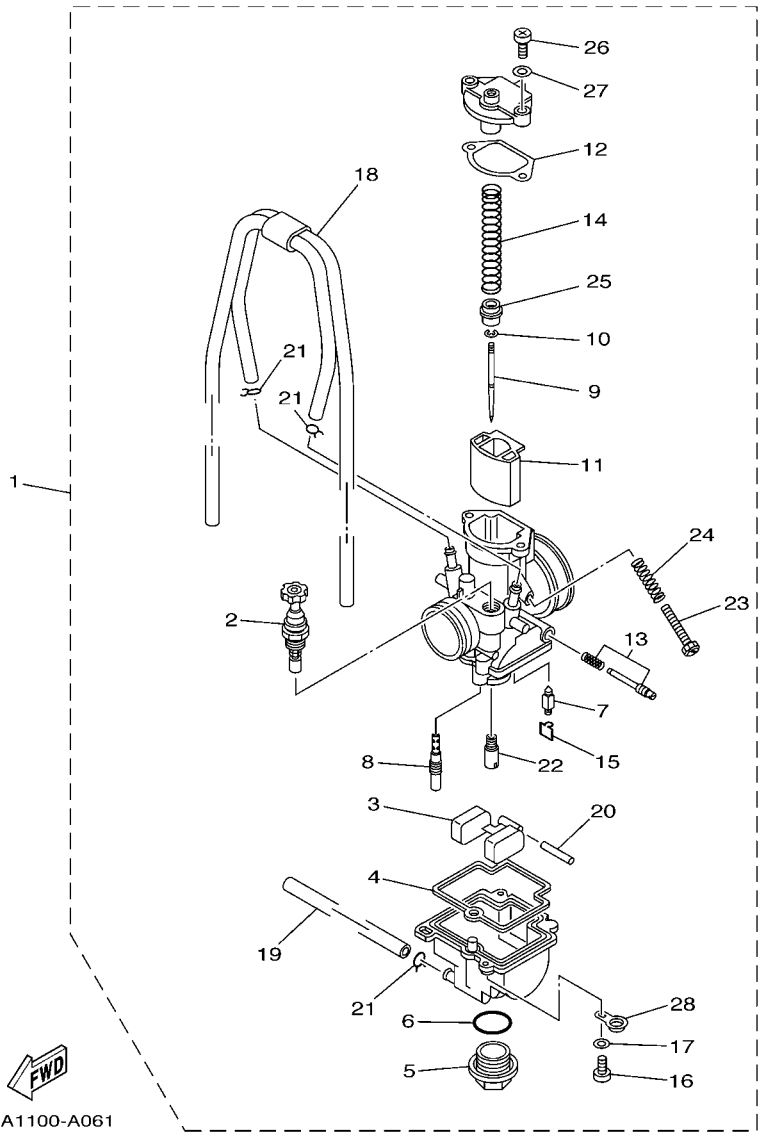

5PA1100-A061

FIG. 6 CARBURETOR

REF. NO.	PART NO.	DESCRIPTION	5PAA	5PAC	5SHA	5SHC	REMARKS
21	3TJ-14137-40	.CLIP	3	3	3	3	
22	4MX-14943-85	.JET, MAIN (#138)	1	1	1	1	STD
	4MX-14943-84	.JET, MAIN (#132)	1	1	1	1	AP
	4MX-14943-34	.JET, MAIN (#135)	1	1	1	1	AP
	4MX-14943-35	.JET, MAIN (#140)	1	1	1	1	AP
	4MX-14943-86	.JET, MAIN (#142)	1	1	1	1	AP
	4MX-14943-36	.JET, MAIN (#145)	1	1	1	1	AP
	4MX-14943-87	.JET, MAIN (#148)	1	1	1	1	AP
23	5HC-14922-00	.SCREW, THROTTLE	1	1	1	1	
24	5HC-14934-00	.SPRING, THROTTLE STOP	1	1	1	1	
25	5PA-14194-00	.RING	1	1	1	1	
26	98504-04012	.SCREW, PAN HEAD	2	2	2	2	
27	92903-04600	.WASHER	2	2	2	2	
28	5PA-14146-00	.PLATE	1	1	1	1	

FIG. 7 EXHAUST

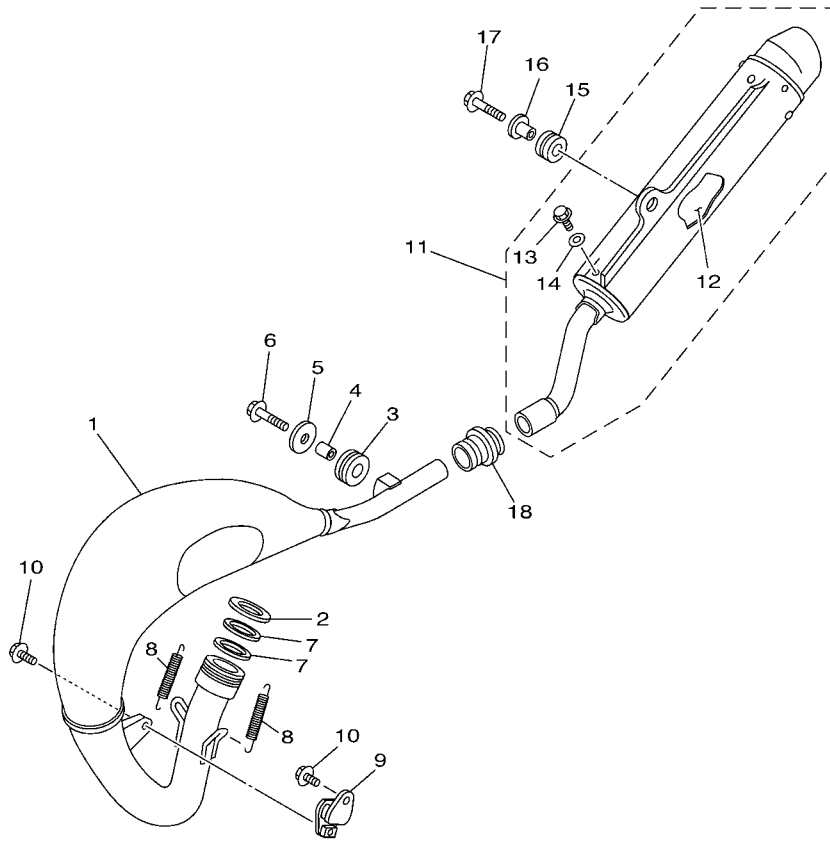

REF. NO.	PART NO.	DESCRIPTION	SPAA	SPAC	SSHA	SSHC	REMARKS
1	5PA-14610-00	EXHAUST PIPE ASSY 1	1	1	1	1	
2	90201-33299	WASHER, PLATE	1	1	1	1	
3	90480-18411	GROMMET	1	1	1	1	
4	90387-105L0	COLLAR	1	1	1	1	
5	90201-060A3	WASHER, PLATE	1	1	1	1	
6	95027-06025	BOLT, FLANGE	1	1	1	1	
7	5PA-14642-00	SEAL, EXHAUST	2	2	2	2	
8	90507-20052	SPRING, TENSION	2	2	2	2	
9	565-14771-00	STAY, MUFFLER 1	1	1	1	1	
10	90119-06001	BOLT, WITH WASHER	2	2	2	2	
11	5PA-14753-00	SILENCER, EXHAUST	1		1		
12	5PA-1469A-00	.FIBER	1		1		
13	92017-06010	.BOLT, BUTTON HEAD	2	2	2	2	
14	90201-06050	.WASHER, PLATE	2	2	2	2	
15	90480-16561	GROMMET	1	1	1	1	
16	90387-063G3	COLLAR	1	1	1	1	
17	95027-06025	BOLT, FLANGE	1	1	1	1	
18	17W-14615-00	JOINT, EXHAUST 1	1	1	1	1	



5PA4100-B070

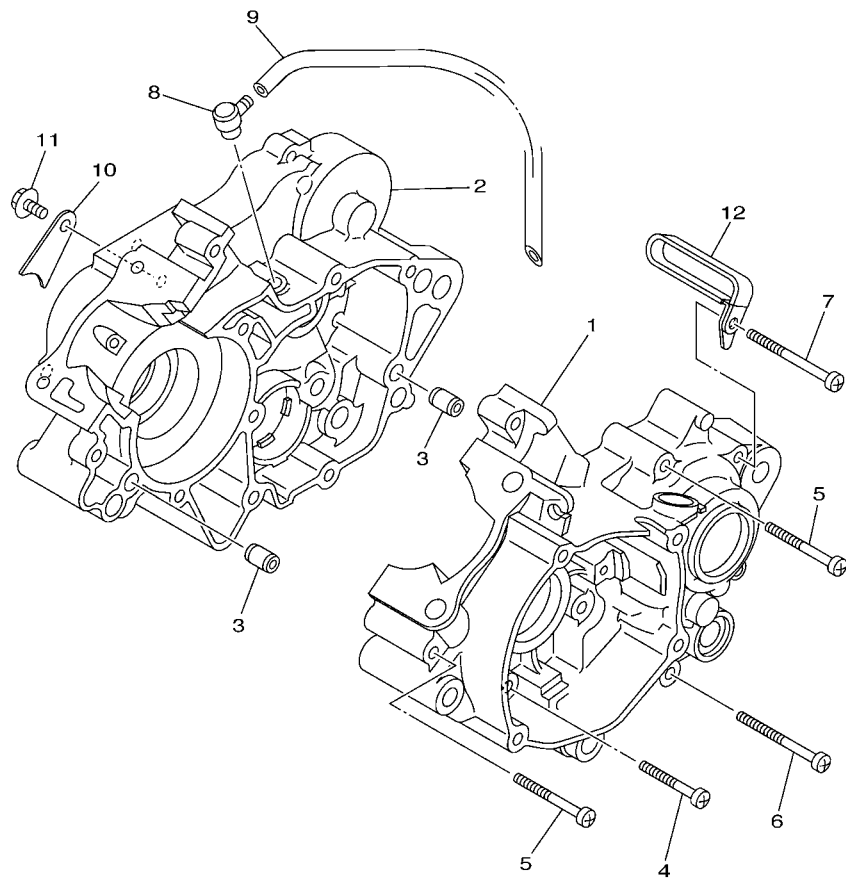
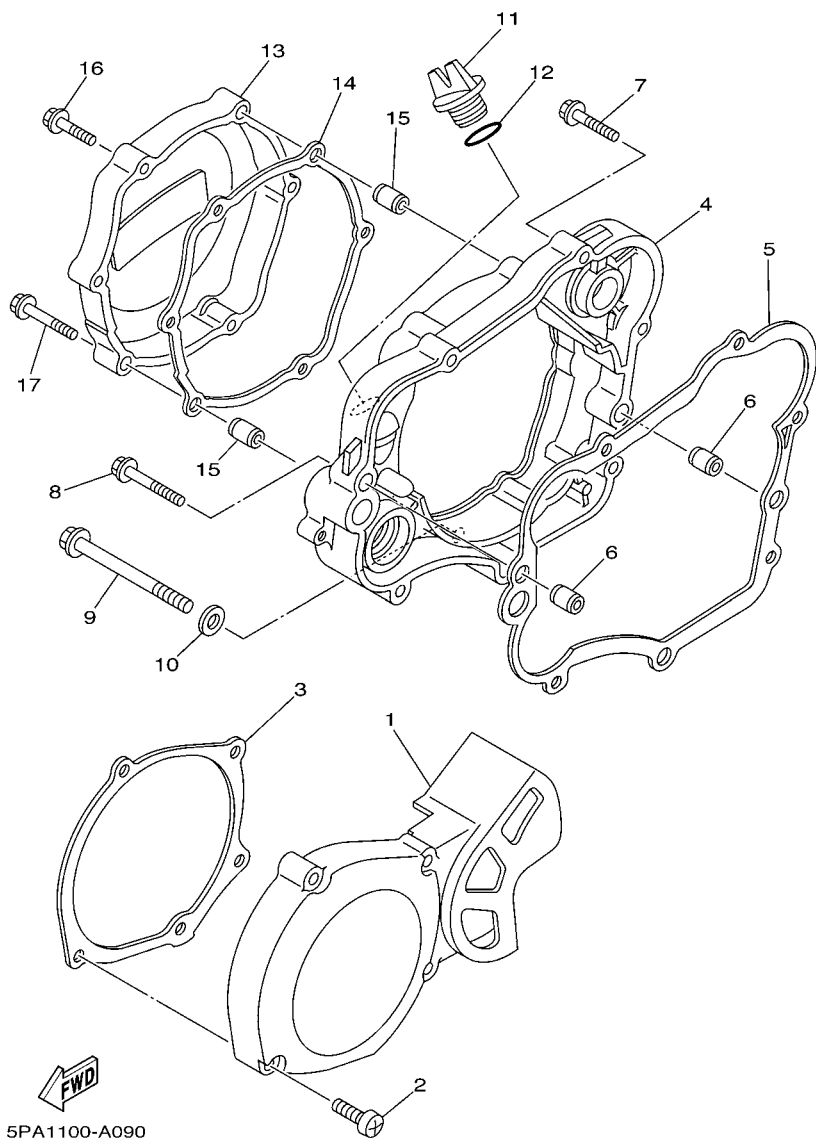

FIG. 8 CRANKCASE

REF. NO.	PART NO.	DESCRIPTION	5PAA	5PAC	5SHA	5SHC	REMARKS
1	5PA-15111-00	CRANKCASE 1	1	1	1	1	
2	5PA-15121-10	CRANKCASE 2	1	1	1	1	
3	99530-10014	PIN, DOWEL	2	2	2	2	
4	98507-06040	SCREW, PAN HEAD	3	3	3	3	
5	98507-06050	SCREW, PAN HEAD	4	4	4	4	
6	98507-06060	SCREW, PAN HEAD	3	3	3	3	
7	98507-06070	SCREW, PAN HEAD	1	1	1	1	
8	353-13115-01	CONNECTOR, SUCTION PIPE	1	1	1	1	
9	90445-08376	HOSE (L330)	1	1	1	1	
10	5PA-15118-00	HOLDER	1	1	1	1	
11	90105-08050	BOLT, FLANGE	1	1	1	1	
12	90461-10136	CLAMP	1	1	1	1	



5PA4100-B080

FIG. 9 CRANKCASE COVER 1

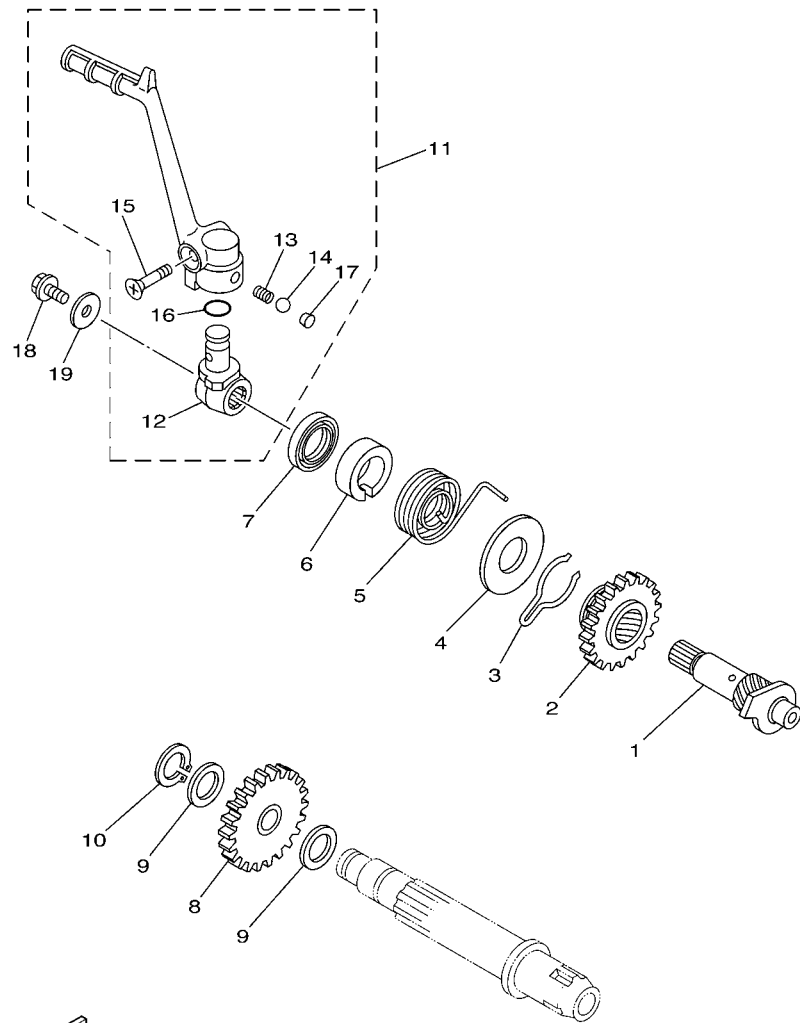

REF. NO.	PART NO.	DESCRIPTION	5PAA	5PAC	5SHA	5SHC	REMARKS
1	4ES-15411-00	COVER, CRANKCASE 1	1	1	1	1	
2	98507-06030	SCREW, PAN HEAD	4	4	4	4	
3	5PA-15451-00	GASKET, CRANKCASE COVER 1	1	1	1	1	
4	5PA-15431-00	COVER, CRANKCASE 3	1	1	1	1	
5	4ES-15461-00	GASKET, CRANKCASE COVER 2	1	1	1	1	
6	99530-10014	PIN, DOWEL	2	2	2	2	
7	95027-06030	BOLT, FLANGE	4	4	4	4	
8	95027-06040	BOLT, FLANGE	1	1	1	1	
9	95027-08080	BOLT, FLANGE	1	1	1	1	
10	90430-08119	GASKET	1	1	1	1	
11	3Y1-15363-00	PLUG, OIL	1	1	1	1	
12	93210-19123	O-RING	1	1	1	1	
13	5PA-15415-00	COVER, GENERATOR	1	1	1	1	
14	5PA-15463-00	GASKET, CARBURETOR COVER 2	1	1	1	1	
15	99530-08016	PIN, DOWEL	2	2	2	2	
16	95027-06025	BOLT, FLANGE	4	4	4	4	
17	95027-06035	BOLT, FLANGE	2	2	2	2	

FIG. 10 STARTER



5PA1100-A100

REF. NO.	PART NO.	DESCRIPTION	5PAA	5PAC	5SHA	5SHC	REMARKS
1	5PA-15660-00	KICK AXLE ASSY	1	1	1	1	
2	5PA-15641-00	GEAR, KICK	1	1	1	1	
3	90468-23194	CLIP	1	1	1	1	
4	90201-176L4	WASHER, PLATE	1	1	1	1	
5	90508-26750	SPRING, TORSION	1	1	1	1	
6	4ES-15664-00	GUIDE, SPRING	1	1	1	1	
7	93102-17263	OIL SEAL	1	1	1	1	
8	5PA-15651-00	GEAR, KICK IDLE	1	1	1	1	
9	90201-124F8	WASHER, PLATE	2	2	2	2	
10	99009-12400	CIRCLIP	1	1	1	1	
11	5PA-15620-00	KICK CRANK ASSY	1	1	1	1	
12	5PA-15621-00	.BOSS, KICK CRANK	1	1	1	1	
13	90501-12081	.SPRING, COMPRESSION	1	1	1	1	
14	93507-32009	.BALL	1	1	1	1	
15	90152-06010	.SCREW, COUNTERSUNK	1	1	1	1	
16	93210-12152	.O-RING	1	1	1	1	
17	90336-06031	.PLUG, TAPER	1	1	1	1	
18	95027-06012	BOLT, FLANGE	1	1	1	1	
19	90201-06060	WASHER, PLATE	1	1	1	1	

FIG. 11 CLUTCH

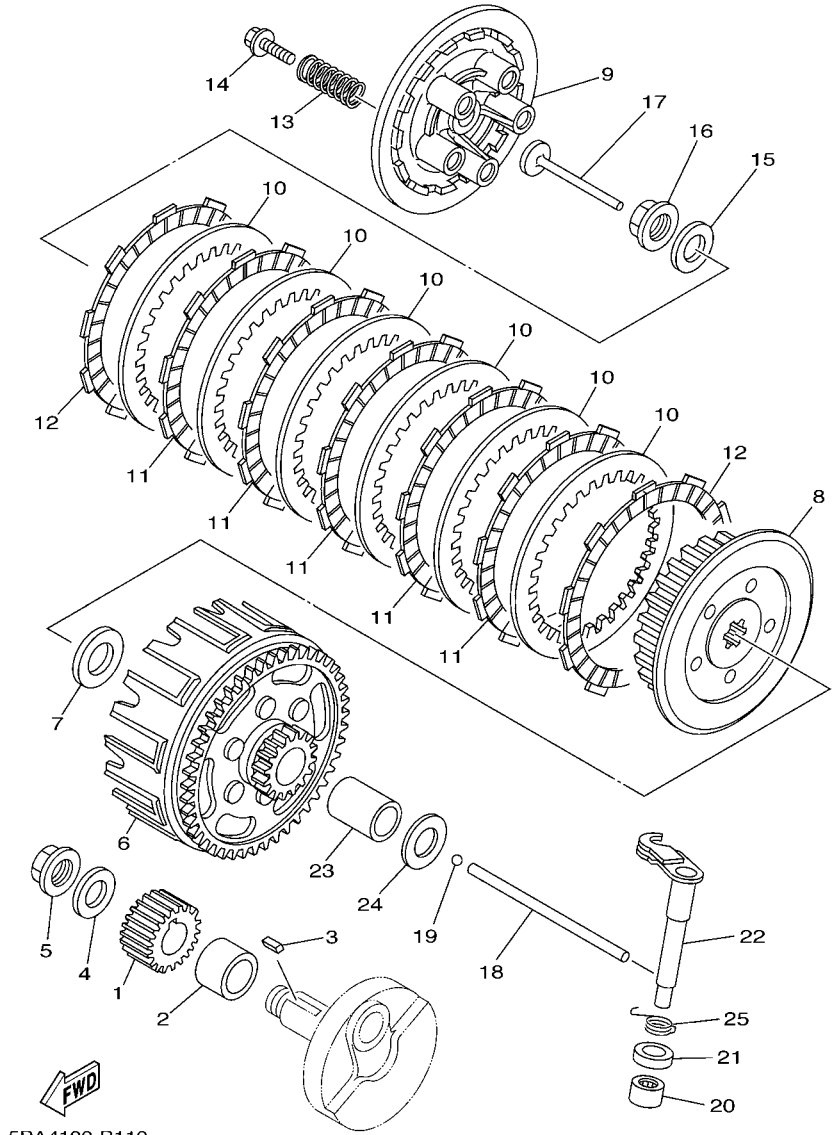

5PA4100-B110

REF. NO.	PART NO.	DESCRIPTION	5PAA	5PAC	5SHA	5SHC	REMARKS
1	5PA-16111-00	GEAR, PRIMARY DRIVE	1	1	1	1	
2	90387-20488	COLLAR	1	1	1	1	
3	90282-05001	KEY, STRAIGHT (5MMX16MM)	1	1	1	1	
4	90208-12015	WASHER, CONICAL SPRING	1	1	1	1	
5	90179-12659	NUT	1	1	1	1	
6	5PA-16150-10	PRIMARY DRIVEN GEAR COMP.	1	1	1	1	
7	90201-17558	WASHER, PLATE	1	1	1	1	
8	5PA-16371-10	BOSS, CLUTCH	1	1	1	1	
9	2TK-16351-00	PLATE, PRESSURE 1	1	1	1	1	
10	131-16324-00	PLATE, CLUTCH 1	6	6	6	6	
11	4ES-16321-00	PLATE, FRICTION	5	5	5	5	
12	21V-16321-00	PLATE, FRICTION	2	2	2	2	
13	90501-204A0	SPRING, COMPRESSION	5	5	5	5	
14	90119-05001	BOLT, WITH WASHER	5	5	5	5	
15	90208-12015	WASHER, CONICAL SPRING	1	1	1	1	
16	90179-12659	NUT	1	1	1	1	
17	4ES-16356-00	ROD, PUSH 1	1	1	1	1	
18	5PA-16357-00	ROD, PUSH 2	1	1	1	1	
19	93503-16003	BALL	1	1	1	1	
20	93315-11206	BEARING	1	1	1	1	
21	93102-12224	OIL SEAL	1	1	1	1	
22	4ES-16381-00	PUSH LEVER COMP.	1	1	1	1	
23	5PA-16181-00	SPACER 1	1	1	1	1	
24	90201-171G6	WASHER, PLATE	1	1	1	1	
25	90508-14016	SPRING, TORSION	1	1	1	1	

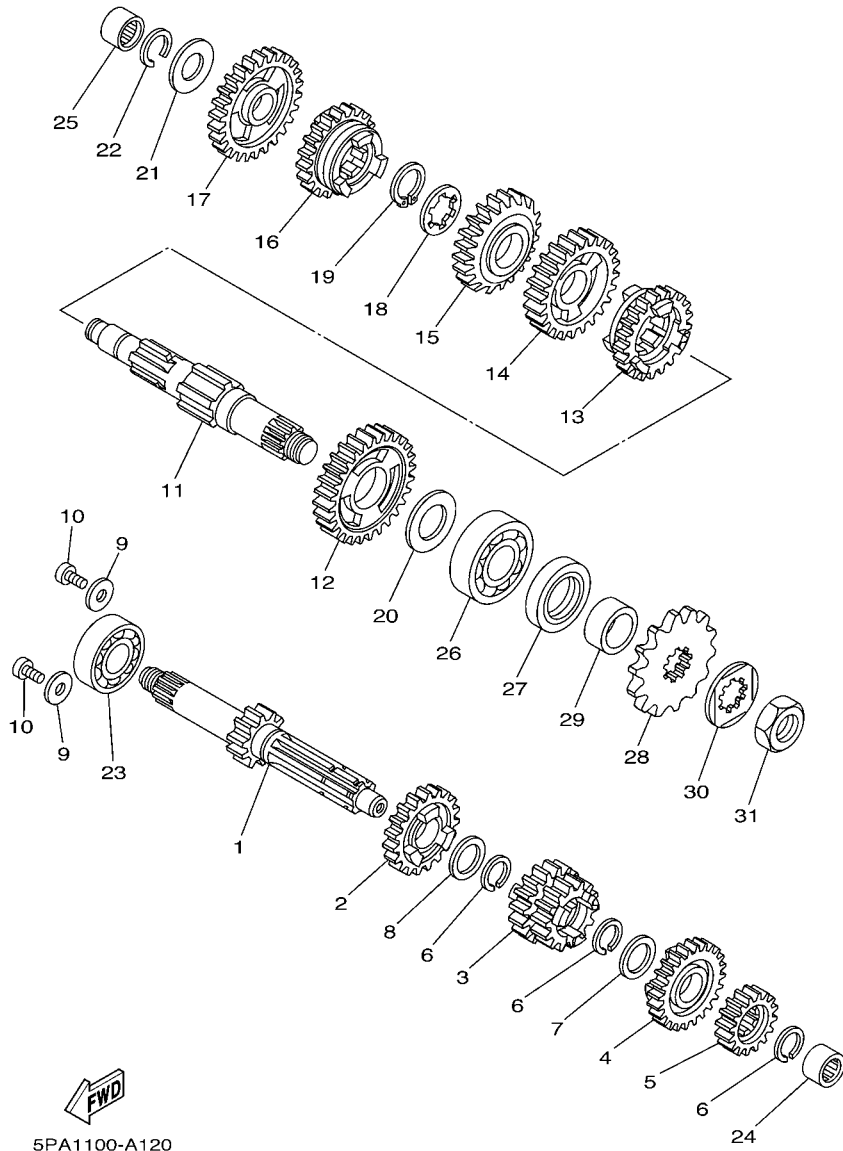
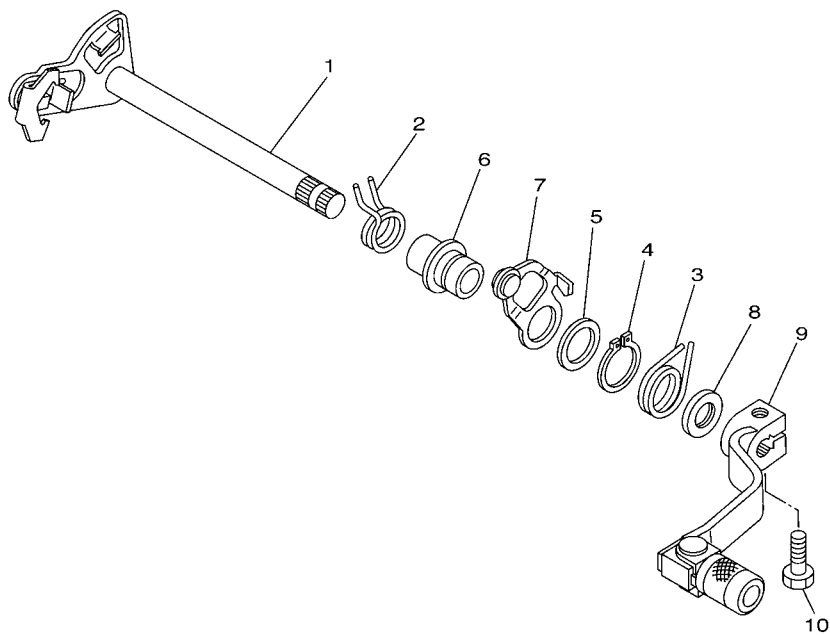

FIG. 12 TRANSMISSION

REF. NO.	PART NO.	DESCRIPTION	5PAA	5PAC	5SHA	5SHC	REMARKS
1	5PA-17411-00	AXLE, MAIN (11T)	1	1	1	1	
2	4ES-17151-10	GEAR, 5TH PINION (23T)	1	1	1	1	
3	4ES-17131-02	GEAR, 3RD PINION (17T/17T)	1	1	1	1	
4	4ES-17161-10	GEAR, 6TH PINION (25T)	1	1	1	1	
5	4ES-17121-01	GEAR, 2ND PINION (17T)	1	1	1	1	
6	93440-17064	CIRCLIP	3	3	3	3	
7	90209-14008	WASHER	1	1	1	1	
8	90201-17545	WASHER, PLATE	1	1	1	1	
9	90201-06060	WASHER, PLATE	2	2	2	2	
10	90157-06071	SCREW, PAN HEAD	2	2	2	2	
11	5PA-17421-00	AXLE, DRIVE	1	1	1	1	
12	5PA-17221-00	GEAR, 2ND WHEEL (32T)	1	1	1	1	
13	5PA-17261-00	GEAR, 6TH WHEEL (25T)	1	1	1	1	
14	4ES-17231-10	GEAR, 3RD WHEEL (26T)	1	1	1	1	
15	5PA-17241-00	GEAR, 4TH WHEEL (22T)	1	1	1	1	
16	4ES-17251-00	GEAR, 5TH WHEEL (26T)	1	1	1	1	
17	4ES-17211-01	GEAR, 1ST WHEEL (27T)	1	1	1	1	
18	90209-16209	WASHER	1	1	1	1	
19	93410-20038	CIRCLIP	1	1	1	1	
20	90201-20611	WASHER, PLATE	1	1	1	1	
21	164-17427-00-06	SHIM 1 (T=0.6)	1	1	1	1	UR
	164-17427-00-08	SHIM 1 (T=0.8)	1	1	1	1	UR
	164-17427-00-10	SHIM 1 (T=1.0)	1	1	1	1	UR
22	93440-15012	CIRCLIP	1	1	1	1	
23	93306-20333	BEARING	1	1	1	1	
24	93317-11245	BEARING	1	1	1	1	
25	93315-31502	BEARING	1	1	1	1	

FIG. 14 SHIFT SHAFT



REF. NO.	PART NO.	DESCRIPTION	5PAA	5PAC	5SHA	5SHC	REMARKS
1	5PA-18101-00	SHIFT SHAFT ASSY	1	1	1	1	
2	90508-32016	SPRING, TORSION	1	1	1	1	
3	90508-24007	SPRING, TORSION	1	1	1	1	
4	99009-17400	CIRCLIP	1	1	1	1	
5	90201-177G4	WASHER, PLATE	1	1	1	1	
6	5PA-1811E-00	COLLAR,SHIFT PEDAL	1	1	1	1	
7	5PA-18140-00	STOPPER LEVER ASSY	1	1	1	1	
8	93101-12173	OIL SEAL	1	1	1	1	
9	2HF-18110-01	SHIFT PEDAL ASSY	1	1	1	1	
10	97027-06020	BOLT	1	1	1	1	



5PA1100-A140

FIG. 15 FRAME

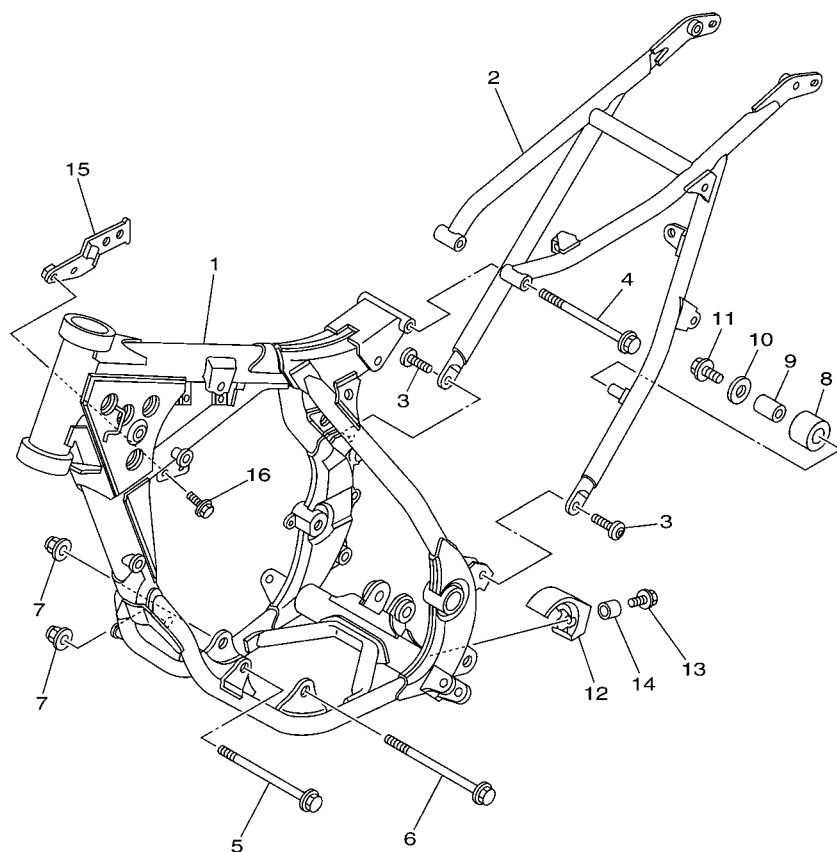

5PA1100-A150

REF. NO.	PART NO.	DESCRIPTION	5PAA	5PAC	5SHA	5SHC	REMARKS
1	5PA-21101-11-P0	FRONT FRAME COMP.	1	1	1	1	DPBMC
2	5PA-21190-00-P0	REAR FRAME COMP.	1	1	1	1	DPBMC
3	90110-08096	BOLT, HEXAGON SOCKET HEAD	2	2	2	2	
4	95817-08125	BOLT, FLANGE	1	1	1	1	
5	90105-10111	BOLT, FLANGE	1	1	1	1	
6	90105-10110	BOLT, FLANGE	1	1	1	1	
7	95607-10200	NUT, U FLANGE	2	2	2	2	
8	30X-22178-00	TENSIONER	1	1	1	1	
9	4V4-22184-00	BUSH	1	1	1	1	
10	90201-081R9	WASHER, PLATE	1	1	1	1	
11	95027-08012	BOLT, FLANGE	1	1	1	1	
12	4ES-22178-00	TENSIONER	1	1	1	1	
13	90119-06118	BOLT, WITH WASHER	1	1	1	1	
14	90387-067K6	COLLAR	1	1	1	1	
15	5PA-21274-00	BRACKET, C.D.I. UNIT	1	1	1	1	
16	95027-06012	BOLT, FLANGE	2	2	2	2	

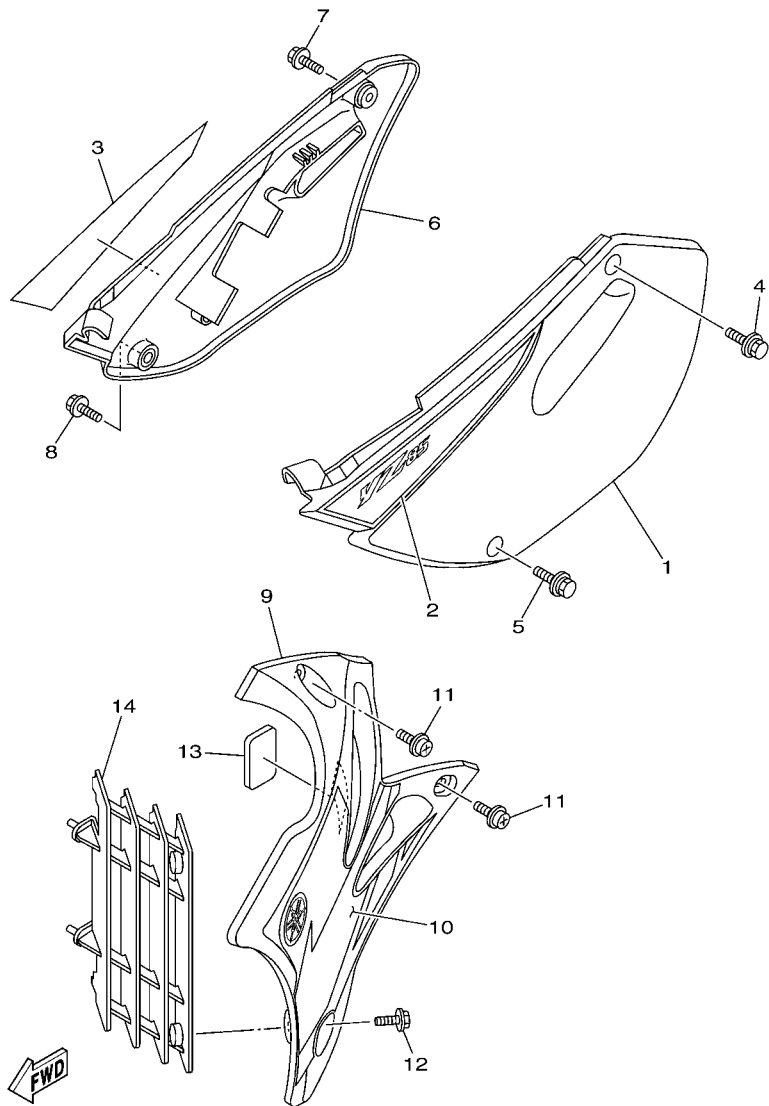

5PAA100-D170

FIG. 17 SIDE COVER

REF. NO.	PART NO.	DESCRIPTION	5PAA	5PAC	5SHA	5SHC	REMARKS
1	5PA-21711-00	COVER, SIDE 1	1	1	1	1	
2	5PA-2173E-10	GRAPHIC 1	1	1	1	1	
3	5PA-2173F-10	GRAPHIC 2	1	1	1	1	
4	90119-06225	BOLT, WITH WASHER	1	1	1	1	
5	90119-06001	BOLT, WITH WASHER	1	1	1	1	
6	5PA-21721-00	COVER, SIDE 2	1	1	1	1	
7	90119-06225	BOLT, WITH WASHER	1	1	1	1	
8	90119-06001	BOLT, WITH WASHER	1	1	1	1	
9	5PA-21731-00	COVER, SIDE 3	1	1	1	1	
10	5PA-24244-30	GRAPHIC, FUEL TANK 1	1	1	1	1	
11	90159-06182	SCREW, WITH WASHER	2	2	2	2	
12	90159-06078	SCREW, WITH WASHER	1	1	1	1	
13	1FK-21746-00	DAMPER	1	1	1	1	
14	5PH-2172A-10	PANEL 1	1	1	1	1	

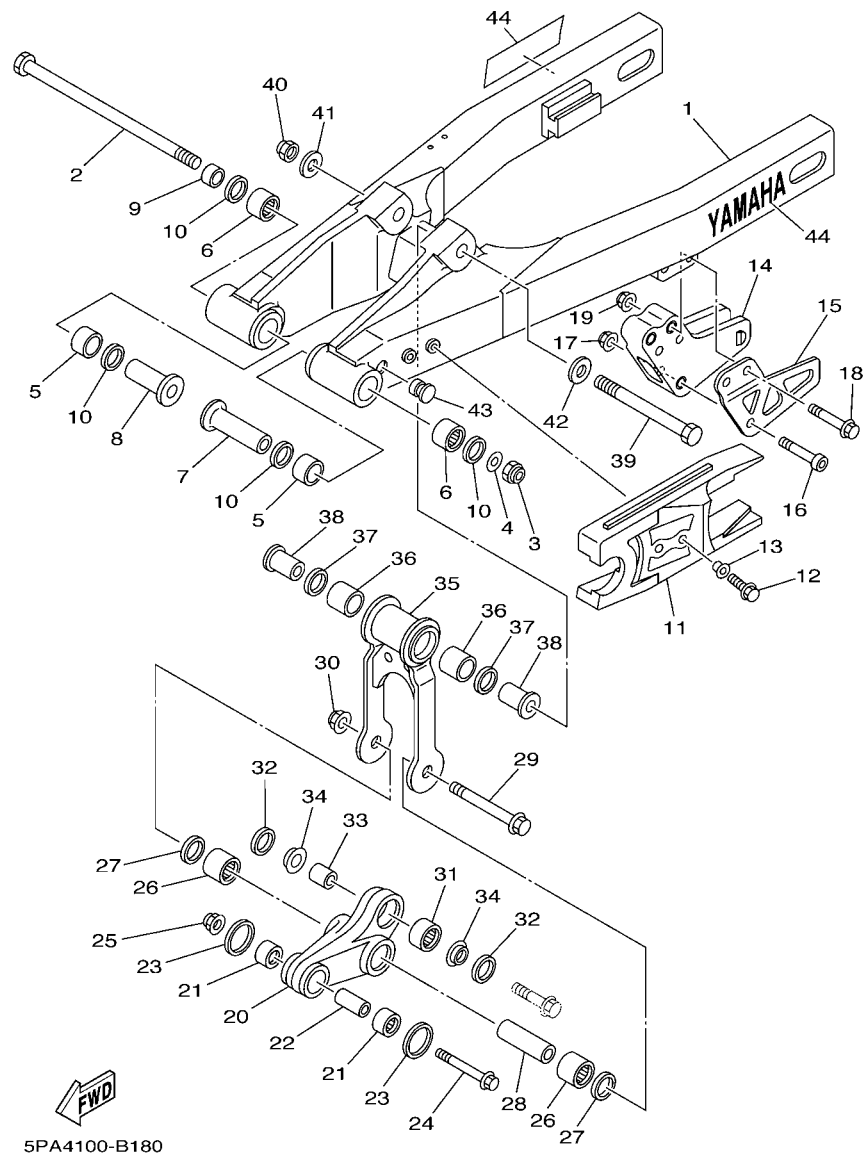

5PA4100-B180

FIG. 18 REAR ARM

REF. NO.	PART NO.	DESCRIPTION	5PAA	5PAC	5SHA	5SHC	REMARKS
1	5PA-22110-00	REAR ARM COMP.	1	1			
	5SH-22110-10	REAR ARM COMP.			1	1	
2	22W-25181-01	AXLE, WHEEL	1	1	1	1	
3	95617-12100	NUT, U	1	1	1	1	
4	90201-124G9	WASHER, PLATE	1	1	1	1	
5	90385-17042	BUSH	2	2	2	2	
6	93317-21746	BEARING	2	2	2	2	
7	90387-127J8	COLLAR	1	1	1	1	
8	90387-127J7	COLLAR	1	1	1	1	
9	90387-1200U	COLLAR	1	1	1	1	
10	93109-17071	OIL SEAL	4	4	4	4	
11	5PA-22151-00	SEAL, GUARD	1	1	1	1	
12	95027-06014	BOLT, FLANGE	2	2	2	2	
13	90387-062X0	COLLAR	2	2	2	2	
14	5PA-22199-00	SUPPORT, CHAIN	1	1	1	1	
15	5PA-22128-00	COVER, THRUST 1	1	1	1	1	
16	92017-06040	BOLT, BUTTON HEAD	1	1	1	1	
17	95607-06200	NUT, SELF U-FLANGE	1	1	1	1	
18	95027-08050	BOLT, FLANGE	2	2	2	2	
19	95607-08200	NUT, SELF-LOCKING	2	2	2	2	
20	5PA-2217A-00	ARM, RELAY	1	1	1	1	
21	93315-21455	BEARING	2	2	2	2	
22	90380-10218	BUSH, SOLID	1	1	1	1	
23	4ES-22129-00	COVER, THRUST 2	2	2	2	2	
24	90105-10582	BOLT, FLANGE	1	1	1	1	
25	95607-10200	NUT, U FLANGE	1	1	1	1	
26	93317-31771	BEARING	2	2	2	2	

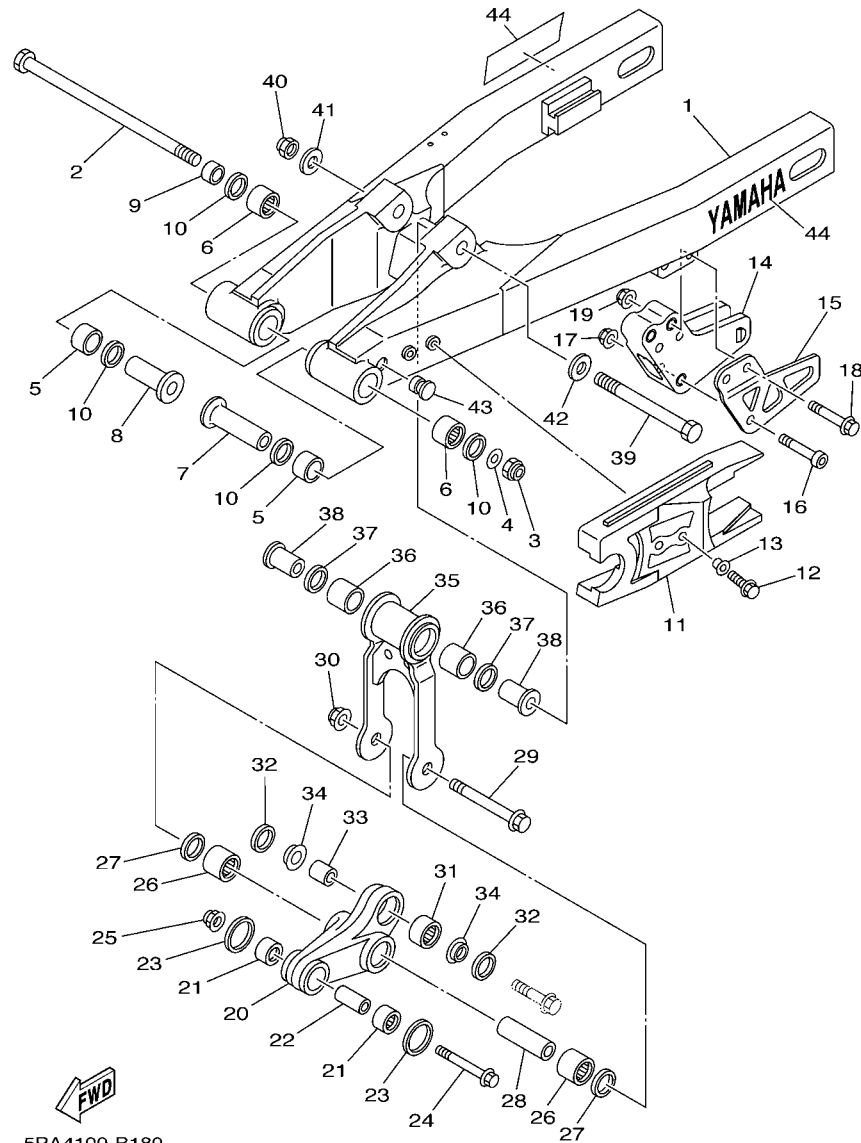

FIG. 18 REAR ARM

REF. NO.	PART NO.	DESCRIPTION	5PAA	5PAC	5SHA	5SHC	REMARKS
27	93101-17062	OIL SEAL	2	2	2	2	
28	90380-12219	BUSH, SOLID	1	1	1	1	
29	90105-12382	BOLT, FLANGE	1	1	1	1	
30	95607-12200	NUT, SELF-LOCKING	1	1	1	1	
31	5PA-22176-00	BEARING	1	1	1	1	
32	5PA-22475-00	SEAL, DUST	2	2	2	2	
33	5PA-22184-00	BUSH	1	1	1	1	
34	5PA-22253-00	COLLAR, DISTANCE	2	2	2	2	
35	4ES-2217F-00	ROD, CONNECTING 1	1	1	1	1	
36	93317-31771	BEARING	2	2	2	2	
37	93101-17062	OIL SEAL	2	2	2	2	
38	90381-12091	BUSH, SOLID	2	2	2	2	
39	90101-12755	BOLT	1	1	1	1	
40	90185-12119	NUT, SELF-LOCKING	1	1	1	1	
41	90201-12749	WASHER, PLATE	1	1	1	1	
42	90201-127J6	WASHER, PLATE	1	1	1	1	
43	90338-10150	PLUG	2	2	2	2	
44	99244-00140	EMBLEM, YAMAHA	2	2	2	2	

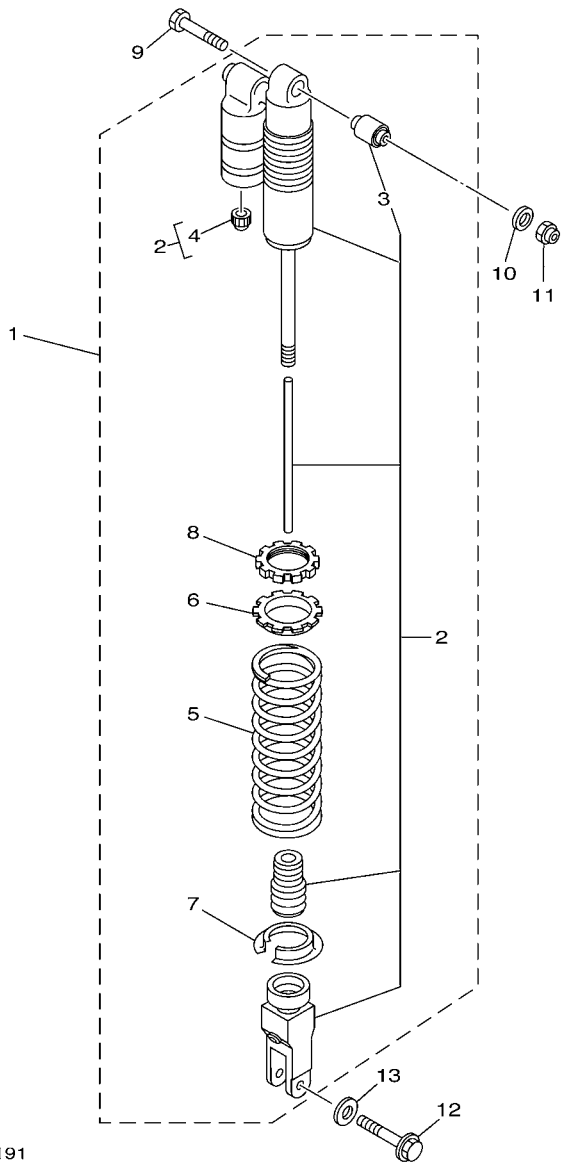
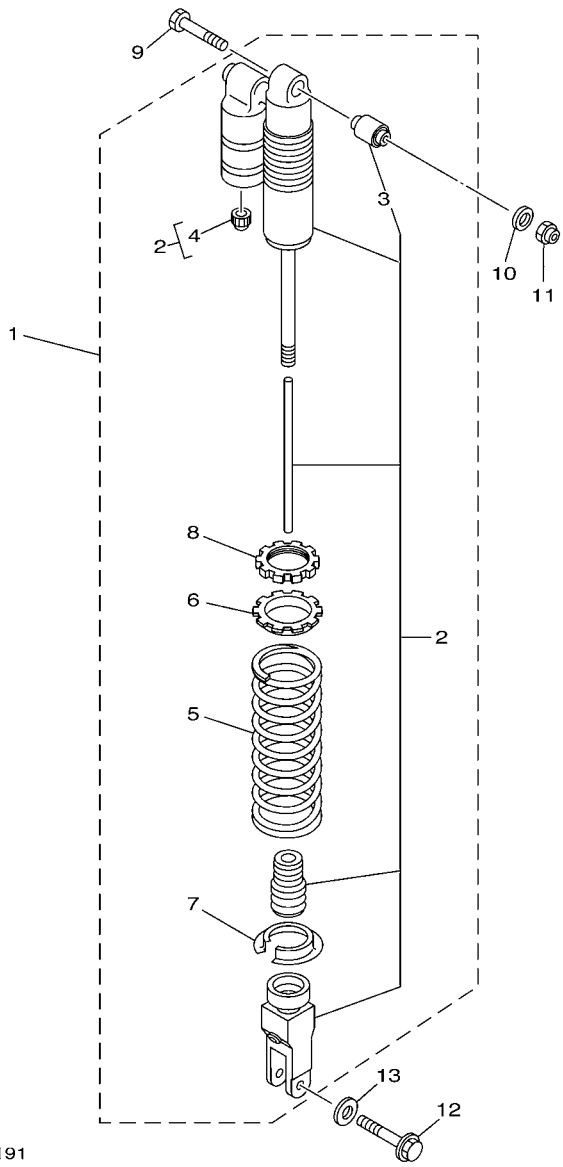

FIG. 19 REAR SUSPENSION

REF. NO.	PART NO.	DESCRIPTION	5PAA	5PAC	5SHA	5SHC	REMARKS
1	5PA-22210-40	SHOCK ABSORBER ASSY, REAR	1				UR FOR ZAF
	5SH-22210-10	SHOCK ABSORBER ASSY, REAR			1		FOR ZAF
2	5PA-22201-40	.DAMPER SUB ASSY	1				UR FOR ZAF
	5SH-22201-10	.DAMPER SUB ASSY			1		FOR ZAF
3	4ES-22216-00	..BUSH, REAR SHOCK ABSORBER	1	1	1	1	
4	58T-23184-L0	..CAP, AIR VALVE	1	1	1	1	
5	4ES-22212-K0	.SPRING (K=45N/MM)	1				UR FOR ZAF
	4ES-22212-G0	.SPRING (K=47N/MM)			1		FOR ZAF
6	4ES-22214-00	.GUIDE, SPRING 1	1	1	1	1	
7	3JD-22214-00	.GUIDE, SPRING 1	1	1	1	1	
8	4ES-22251-00	.NUT 1	1	1	1	1	
9	90109-10729	BOLT	1	1	1	1	
10	92907-10600	WASHER, PLATE	1	1	1	1	
11	90185-10110	NUT, SELF-LOCKING	1	1	1	1	
12	90105-10614	BOLT, FLANGE	1	1	1	1	



FWD
5PA1100-A191

FIG. 19 REAR SUSPENSION

REF. NO.	PART NO.	DESCRIPTION	5PAA	5PAC	5SHA	5SHC	REMARKS
13	90201-112U6	WASHER, PLATE	1	1	1	1	

FIG. 20 STEERING

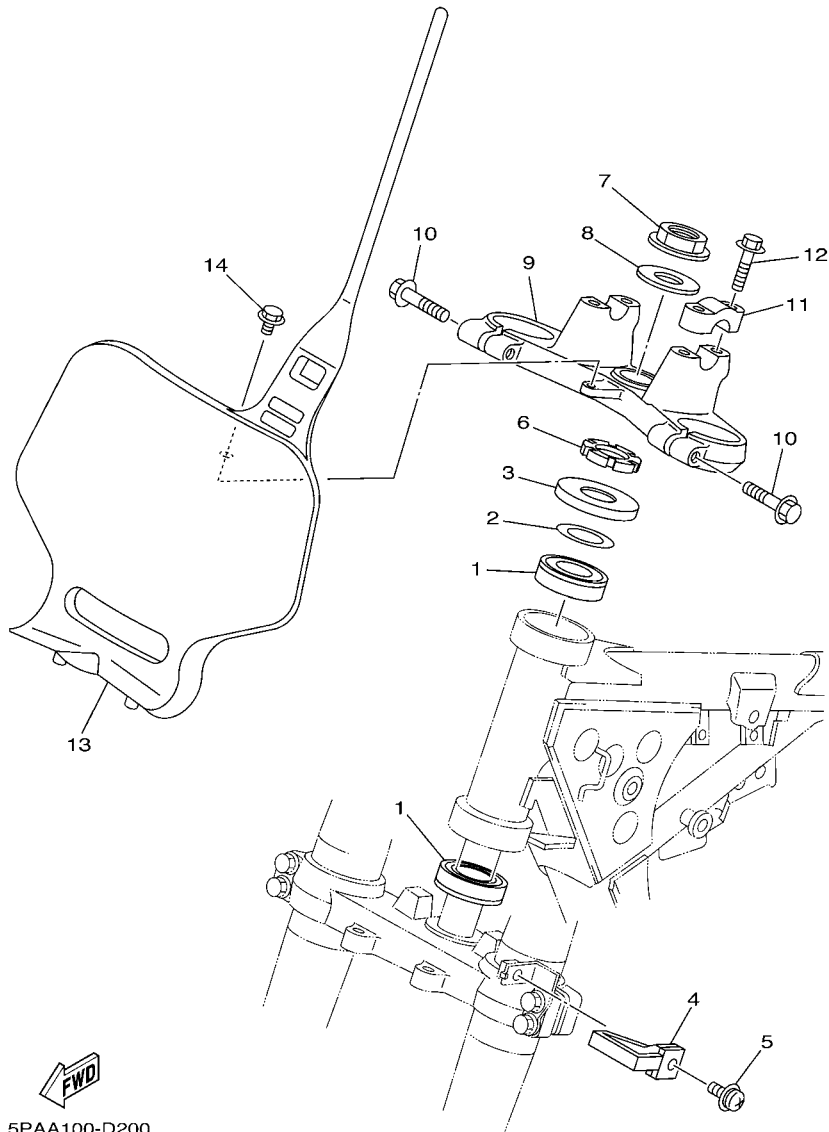

5PAA100-D200

REF. NO.	PART NO.	DESCRIPTION	9PAA	9PAC	5SHA	5SHC	REMARKS
1	93332-00079	BEARING	2	2	2	2	
2	90201-256K5	WASHER, PLATE (0.5T)	1	1	1	1	
3	1J7-23415-00	COVER, BALL RACE 1	1	1	1	1	
4	4DA-23389-00	GUIDE, CABLE	1	1	1	1	
5	90157-05079	SCREW, PAN HEAD	1	1	1	1	
6	90179-25033	NUT	1	1	1	1	
7	90179-22412	NUT	1	1	1	1	
8	90201-220T0	WASHER, PLATE	1	1	1	1	
9	4ES-23435-00	CROWN, HANDLE	1	1	1	1	
10	95807-08035	BOLT, FLANGE	2	2	2	2	
11	3SP-23441-00	HOLDER, HANDLE UPPER	2	2	2	2	
12	95027-08030	BOLT, FLANGE	4	4	4	4	
13	4ES-23485-00	PLATE, NUMBER	1	1	1	1	
14	95027-06012	BOLT, FLANGE	1	1	1	1	

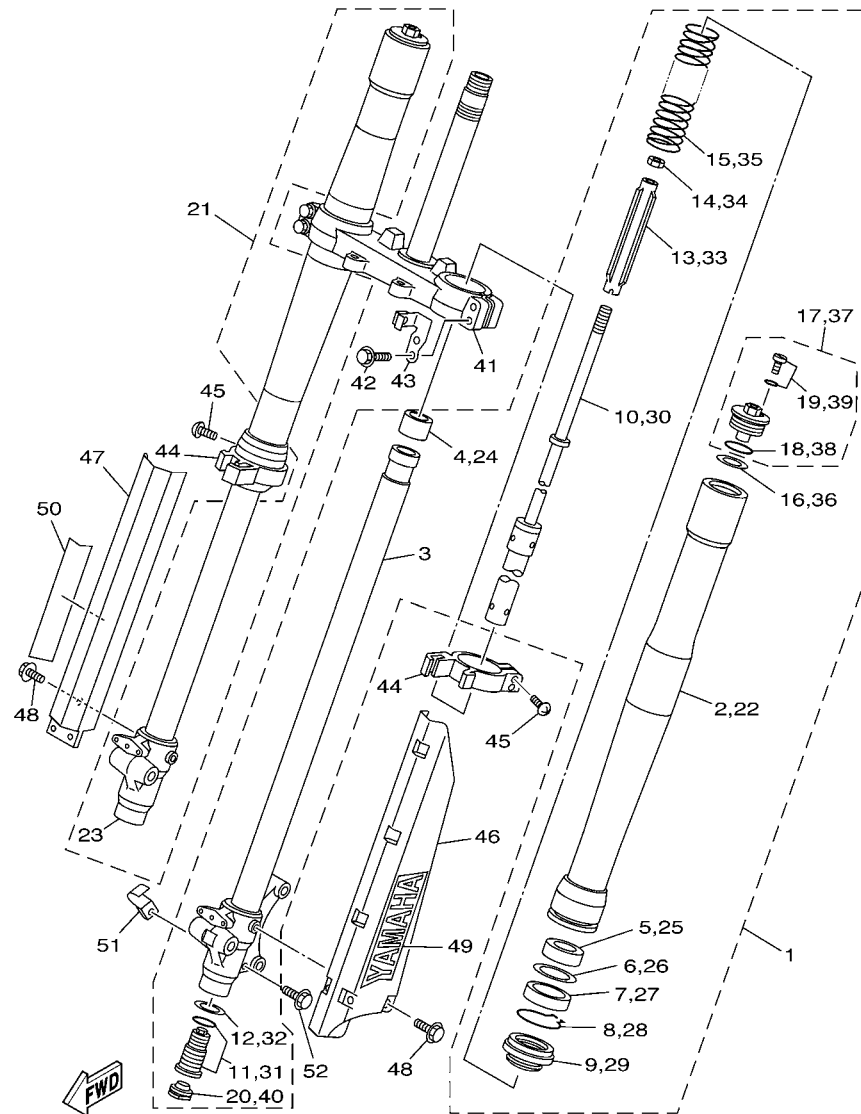

5PA7100-C210

FIG. 21 FRONT FORK

REF. NO.	PART NO.	DESCRIPTION	5PAA	5PAC	5SHA	5SHC	REMARKS
1	5PA-23102-00	FRONT FORK ASSY (L.H)	1	1			
	5SH-23102-00	FRONT FORK ASSY (L.H)			1	1	
2	5PA-23136-00	.TUBE, OUTER (RIGHT)	1	1	1	1	
3	5PA-23120-00	.INNER TUBE COMP.2	1	1	1	1	
4	5PA-23171-00	.PISTON, FRONT FORK	1	1	1	1	
5	5PA-23125-00	.METAL, SLIDE 1	1	1	1	1	
6	5K5-23149-00	.WASHER, SPRING UPPER	1	1	1	1	
7	4ES-23145-00	.OIL SEAL	1	1	1	1	
8	4A1-23156-00	.CLIP, OIL SEAL	1	1	1	1	
9	4ES-23144-00	.SEAL, DUST	1	1	1	1	
10	5PA-23170-00	.CYLINDER COMP., FRONT FORK	1	1	1	1	
11	5PA-2316A-00	.VALVE COMP.	1	1			
	5SH-2316A-00	.VALVE COMP.			1	1	
12	2HH-23158-L0	.GASKET	1	1	1	1	
13	4ES-23142-00	.SEAT, SPRING UPPER	1	1	1	1	
14	3XJ-23357-L0	.NUT	1	1	1	1	
15	4ES-23141-40	.SPRING, FRONT FORK(K=2.8N/MM)	1	1			
	4LB-23141-10	.SPRING, FRONT FORK(K=2.9N/MM)			1	1	
16	5PA-23149-00	.WASHER, SPRING UPPER	1	1	1	1	
17	4ES-23111-10	.BOLT, CAP	1	1	1	1	
18	4V4-23188-L0	.O-RING	1	1	1	1	
19	3JD-23394-00	.BOLT, SPECIAL	1	1	1	1	
20	3JD-2312G-L0	.PLUG	1	1	1	1	
21	5PA-23103-00	FRONT FORK ASSY (R.H)	1	1			
	5SH-23103-00	FRONT FORK ASSY (R.H)			1	1	
22	5PA-23136-00	.TUBE, OUTER (RIGHT)	1	1	1	1	
23	5PA-23110-00	.INNER TUBE COMP.1	1	1	1	1	

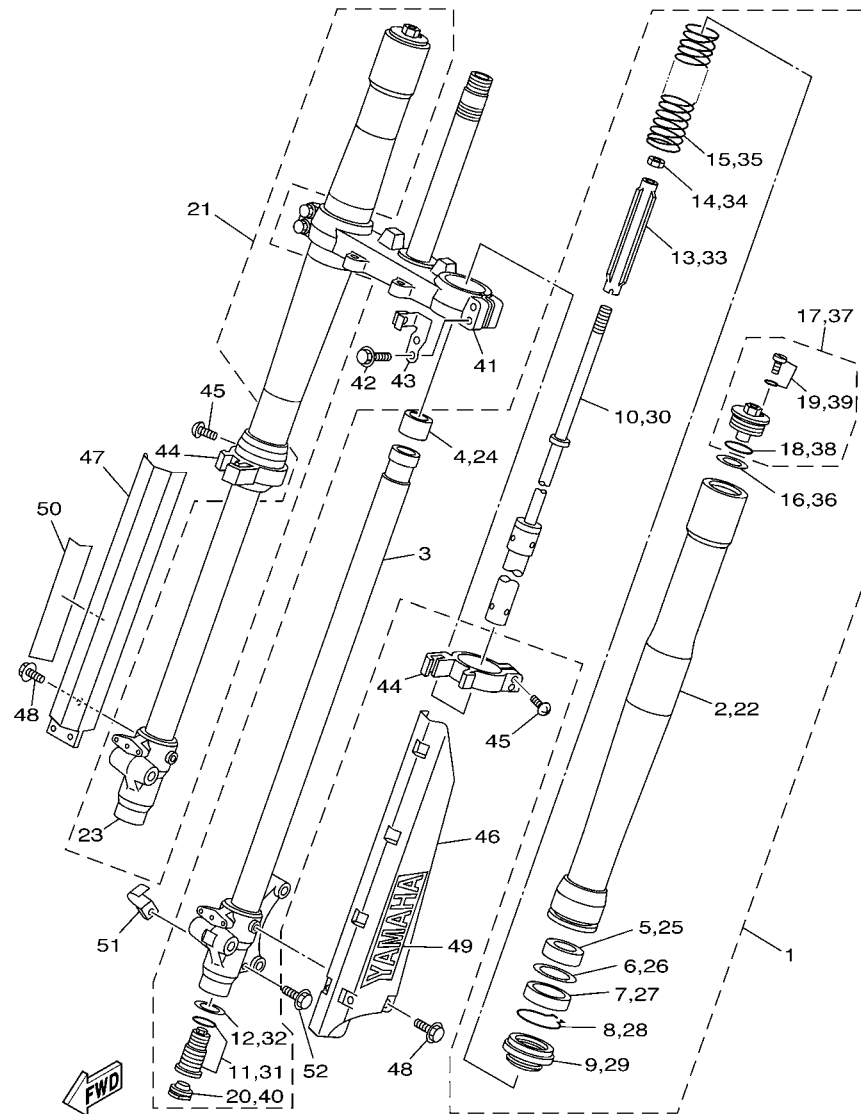

5PA7100-C210

FIG. 21 FRONT FORK

REF. NO.	PART NO.	DESCRIPTION	5PAA	5PAC	5SHA	5SHC	REMARKS
24	5PA-23171-00	.PISTON, FRONT FORK	1	1	1	1	
25	5PA-23125-00	.METAL, SLIDE 1	1	1	1	1	
26	5K5-23149-00	.WASHER, SPRING UPPER	1	1	1	1	
27	4ES-23145-00	.OIL SEAL	1	1	1	1	
28	4A1-23156-00	.CLIP, OIL SEAL	1	1	1	1	
29	4ES-23144-00	.SEAL, DUST	1	1	1	1	
30	5PA-23170-00	.CYLINDER COMP., FRONT FORK	1	1	1	1	
31	5PA-2316A-00	.VALVE COMP.	1	1			
	5SH-2316A-00	.VALVE COMP.			1	1	
32	2HH-23158-L0	.GASKET	1	1	1	1	
33	4ES-23142-00	.SEAT, SPRING UPPER	1	1	1	1	
34	3XJ-23357-L0	.NUT	1	1	1	1	
35	4ES-23141-40	.SPRING, FRONT FORK(K=2.8N/MM)	1	1			
	4LB-23141-10	.SPRING, FRONT FORK(K=2.9N/MM)			1	1	
36	5PA-23149-00	.WASHER, SPRING UPPER	1	1	1	1	
37	4ES-23111-10	.BOLT, CAP	1	1	1	1	
38	4V4-23188-L0	..O-RING	1	1	1	1	
39	3JD-23394-00	..BOLT, SPECIAL	1	1	1	1	
40	3JD-2312G-L0	.PLUG	1	1	1	1	
41	5PA-23340-01	UNDER BRACKET COMP.	1	1	1	1	
42	5NY-23346-L0	BOLT 1	4	4	4	4	
43	5PA-2331E-00	GUIDE, CABLE	1	1	1	1	
44	4ES-2314F-00	PROTECTOR GUIDE COMP, 1	2	2	2	2	
45	4V4-23194-L0	SCREW, BOOT BAND	4	4	4	4	
46	5PA-2314H-L0	PROTECTOR COMP, 1	1	1	1	1	
47	5PA-2314J-L0	PROTECTOR COMP, 2	1	1	1	1	
48	95024-06010	BOLT, FLANGE	6	6	6	6	

FIG. 22 FUEL TANK

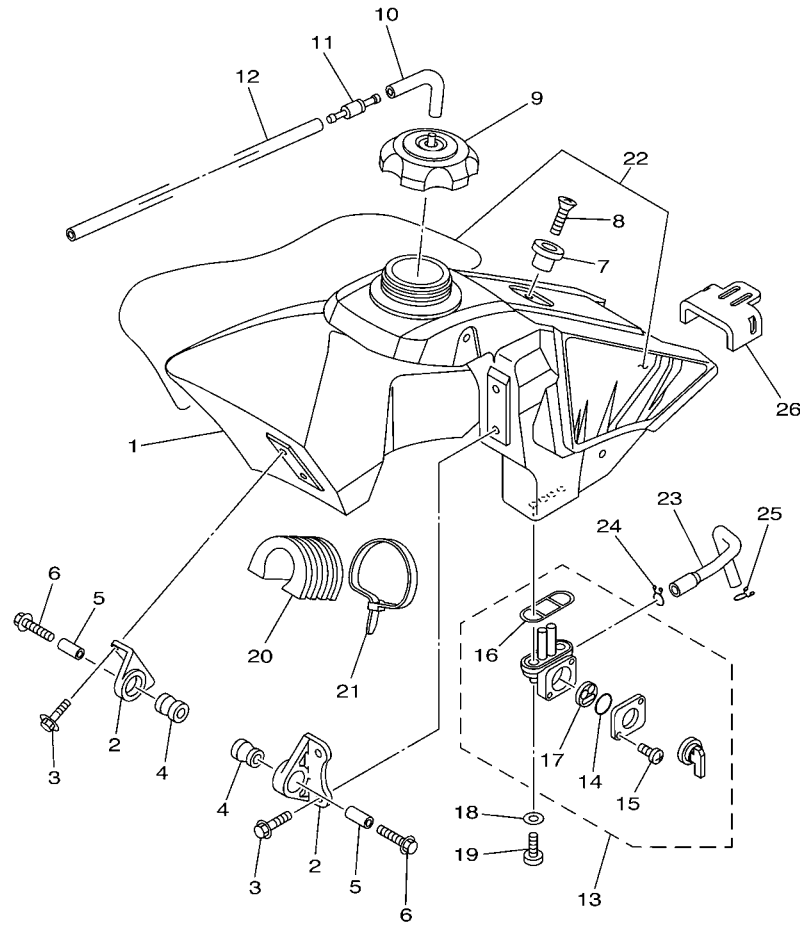

REF. NO.	PART NO.	DESCRIPTION	5PAA	5PAC	5SHA	5SHC	REMARKS
1	5PA-24110-11	FUEL TANK COMP.	1	1	1	1	
2	24X-24144-00	HOLDER, DAMPER	2	2	2	2	
3	95027-06016	BOLT, FLANGE	4	4	4	4	
4	90480-18549	GROMMET	2	2	2	2	
5	90387-06027	COLLAR	2	2	2	2	
6	90119-06190	BOLT, WITH WASHER	2	2	2	2	
7	4EW-2412F-00	BRACKET, SEAT	1	1	1	1	
8	98707-06025	SCREW, FLAT HEAD	1	1	1	1	
9	5NY-24610-00	CAP ASSY	1	1	1	1	
10	90445-09220	HOSE (L30)	1	1	1	1	
11	3XJ-24380-00	PIPE JOINT ASSY	1	1	1	1	
12	90445-09300	HOSE (L355)	1	1	1	1	
13	4DP-24500-01	FUEL COCK ASSY 1	1	1	1	1	
14	3AJ-24534-01	.SEAL, COCK	1	1	1	1	
15	98507-03008	.SCREW, PAN HEAD	2	2	2	2	
16	4X8-24512-00	.O-RING	1	1	1	1	
17	3AC-24523-00	.VALVE PACKING	1	1	1	1	
18	90202-05193	WASHER, PLATE	2	2	2	2	
19	90149-06011	SCREW	2	2	2	2	
20	5PA-24182-00	DAMPER, LOCATING 2	1	1	1	1	
21	90465-13275	CLAMP	1	1	1	1	
22	5PA-24240-30	GRAPHIC SET	1	1	1	1	
23	5PA-24311-00	PIPE, FUEL 1	1	1	1	1	
24	90467-10008	CLIP	1	1	1	1	
25	90467-09002	CLIP	1	1	1	1	
26	5PA-24181-00	DAMPER, LOCATING 1	1	1	1	1	



5PAA100-D220

FIG. 24 FRONT WHEEL

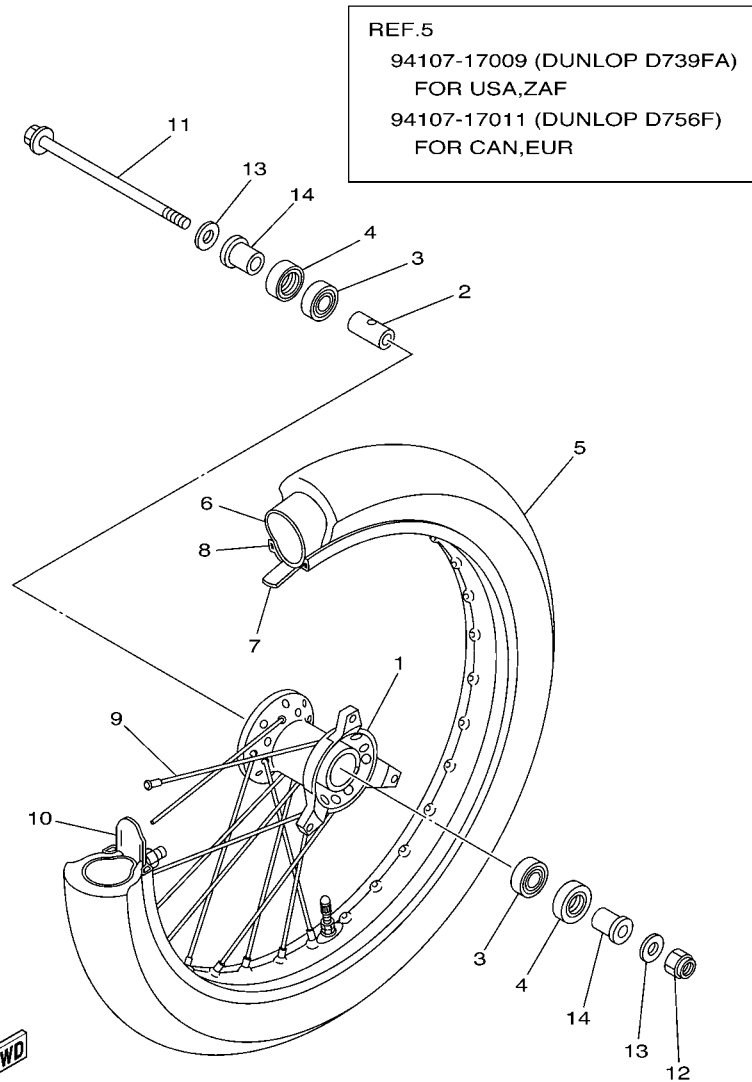

REF.5
 94107-17009 (DUNLOP D739FA)
 FOR USA,ZAF
 94107-17011 (DUNLOP D756F)
 FOR CAN,EUR

FWD
 5PAA100-D240

REF. NO.	PART NO.	DESCRIPTION	5PAA	5PAC	5SHA	5SHC	REMARKS
1	4ES-25111-00	HUB, FRONT	1	1	1	1	
2	90387-124H0	COLLAR	1	1	1	1	
3	93306-20120	BEARING	2	2	2	2	
4	93106-20031	OIL SEAL	2	2	2	2	
5	L.M.	TYRE (70/100-17 40M D739FA)	1	1			
	L.M.	TYRE (70/100-19 42M D756F)			1		
6	L.M.	TUBE (70/100-17M/C TR4)	1	1			
	L.M.	TUBE (70/100-19M/C TR4)			1	1	
7	94307-17166	BAND, RIM (80/90,70/100-17)	1	1			
	94307-19170	BAND, RIM (70/100-19)			1	1	
8	94414-17530	RIM (1.40-17)	1	1			
	94414-19521	RIM (1.40-19)			1	1	
9	4ES-25104-20	SPOKE SET, FRONT	1	1			
	4LB-25104-00	SPOKE SET, FRONT			1	1	
10	1T1-25194-00	SPACER, BEAD	1	1	1	1	
11	4ES-25181-00	AXLE, WHEEL	1	1	1	1	
12	90185-12046	NUT, SELF-LOCKING	1	1	1	1	
13	90201-12362	WASHER, PLATE	2	2	2	2	
14	4ES-25183-10	COLLAR, WHEEL	2	2	2	2	

FIG. 25 FRONT BRAKE CALIPER

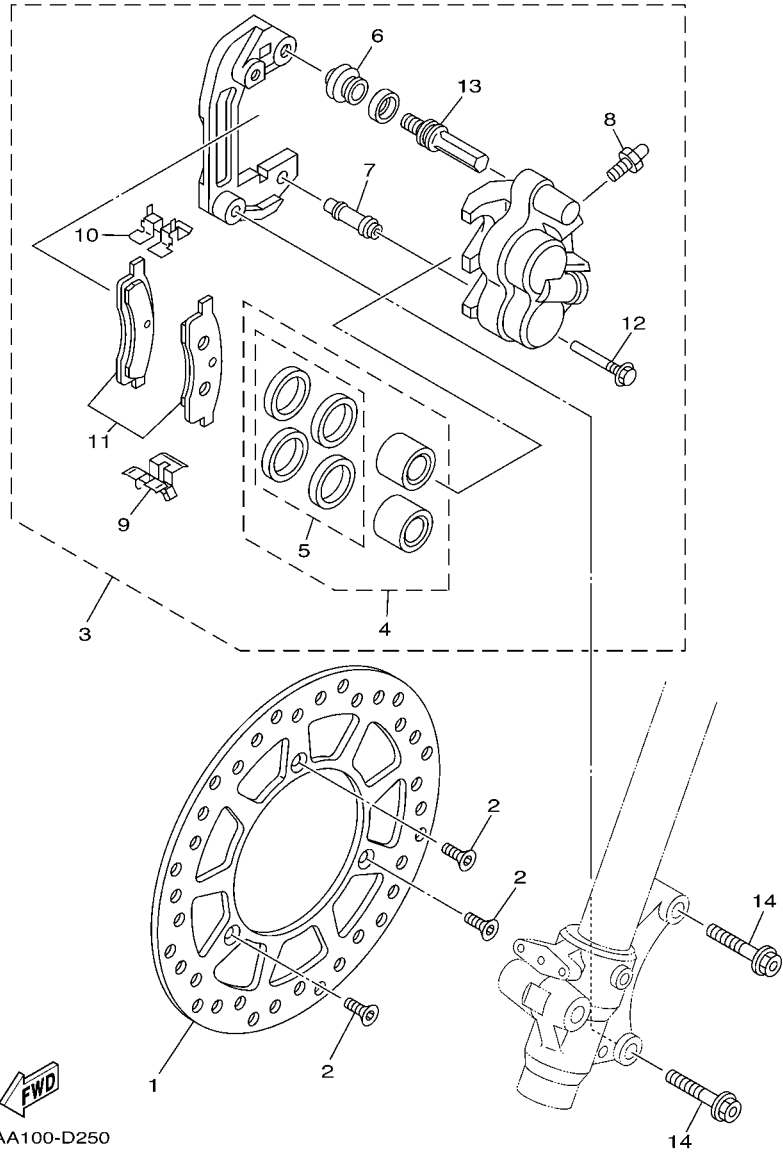

REF. NO.	PART NO.	DESCRIPTION	5PAA	5PAC	5SHA	5SHC	REMARKS
1	5PA-2582T-00	DISC, BRAKE (LEFT)	1	1	1	1	
2	90149-06327	SCREW	3	3	3	3	
3	5PA-2580T-00	CALIPER ASSY (LEFT)	1	1	1	1	
4	4ES-W0057-10	.PISTON ASSY, CALIPER	1	1	1	1	
5	4ES-W0047-10	..CALIPER SEAL KIT	1	1	1	1	
6	5R2-25937-00	.BOOT 2	1	1	1	1	
7	56A-25937-00	.BOOT 2	1	1	1	1	
8	51L-W0048-00	.BLEED SCREW KIT	1	1	1	1	
9	56A-25919-00	.SUPPORT, PAD	1	1	1	1	
10	56A-25919-10	.SUPPORT, PAD	1	1	1	1	
11	5PA-W0045-00	.BRAKE PAD KIT	1	1	1	1	
12	56A-25926-00	.BOLT	1	1	1	1	
13	34X-25914-00	.PIN, SLIDE	1	1	1	1	
14	90105-08211	BOLT, FLANGE	2	2	2	2	

FIG. 26 REAR WHEEL

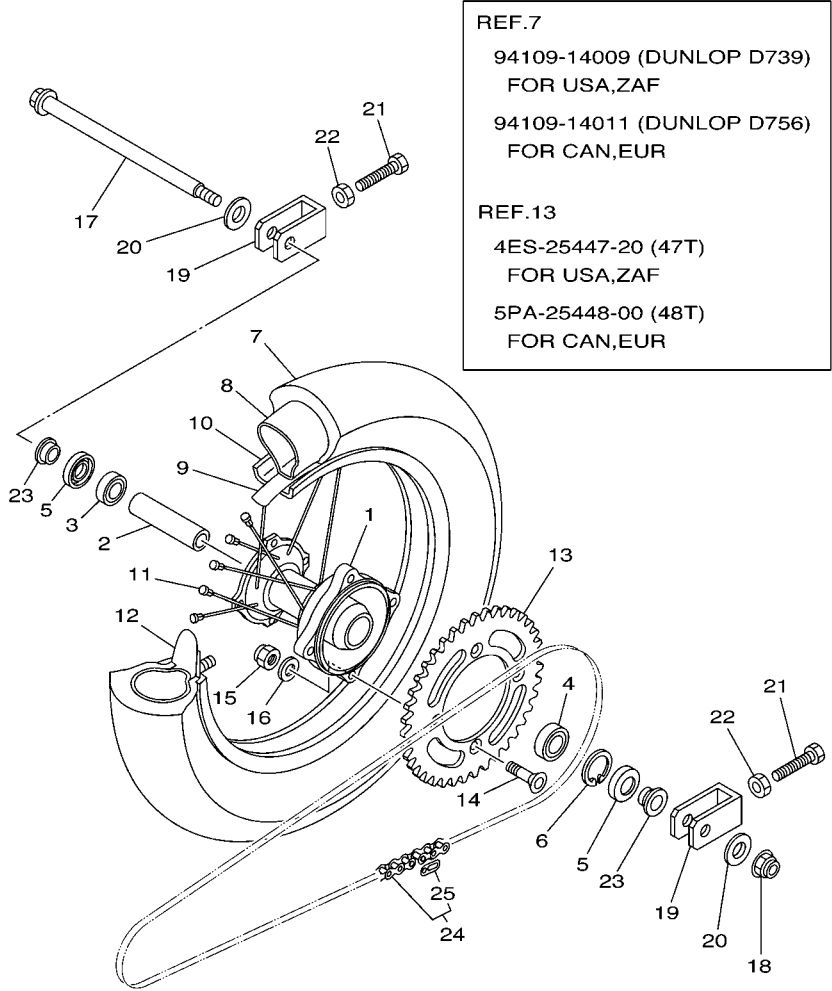

REF.7
 94109-14009 (DUNLOP D739)
 FOR USA,ZAF
 94109-14011 (DUNLOP D756)
 FOR CAN,EUR

REF.13
 4ES-25447-20 (47T)
 FOR USA,ZAF
 5PA-25448-00 (48T)
 FOR CAN,EUR

FWD
 5PAA100-D260

REF. NO.	PART NO.	DESCRIPTION	5PAA	5PAC	5SHA	5SHC	REMARKS
1	4ES-25311-00	HUB, REAR	1	1	1	1	
2	4ES-25383-00	COLLAR, WHEEL	1	1	1	1	
3	93306-00203	BEARING (B6002)	1	1	1	1	
4	93306-20203	BEARING (B6202RS)	1	1	1	1	
5	93102-20009	OIL SEAL	2	2	2	2	
6	99009-35500	CIRCLIP	1	1	1	1	
7	L.M.	TYRE (90/100-14 49M D739)	1	1			
	L.M.	TYRE (90/100-16 52M D756)			1		
8	L.M.	TUBE (80-90/100-14M/C TR4)	1	1			
	L.M.	TUBE (90/100-16M/C TR4)			1	1	
9	94308-14165	BAND, RIM (80-90/100-14)	1	1			
	94307-16171	BAND, RIM (70-90/100-16)			1	1	
10	94416-14529	RIM (1.60-14)	1	1			
	94418-16522	RIM (1.85-16)			1	1	
11	4ES-25304-20	SPOKE SET, REAR	1	1			
	4LB-25304-00	SPOKE SET, REAR			1	1	
12	5X2-25394-00	SPACER, BEAD	1	1			
	1T2-25394-00	SPACER, BEAD			1	1	
13	4ES-25447-20	SPROCKET, DRIVEN (47T)	1	1			UR STD AFAM
	5PA-25448-00	SPROCKET, DRIVEN (48T)	1				UR STD
	5PA-25446-00	SPROCKET, DRIVEN (46T)	1	1			AP
	5PA-25448-00	SPROCKET, DRIVEN (48T)	1	1			AP
	5PA-25449-00	SPROCKET, DRIVEN (49T)	1				AP
	5PA-25452-00	SPROCKET, DRIVEN (52T)			1	1	STD
	5PA-25451-00	SPROCKET, DRIVEN (51T)			1	1	AP

FIG. 27 REAR BRAKE CALIPER

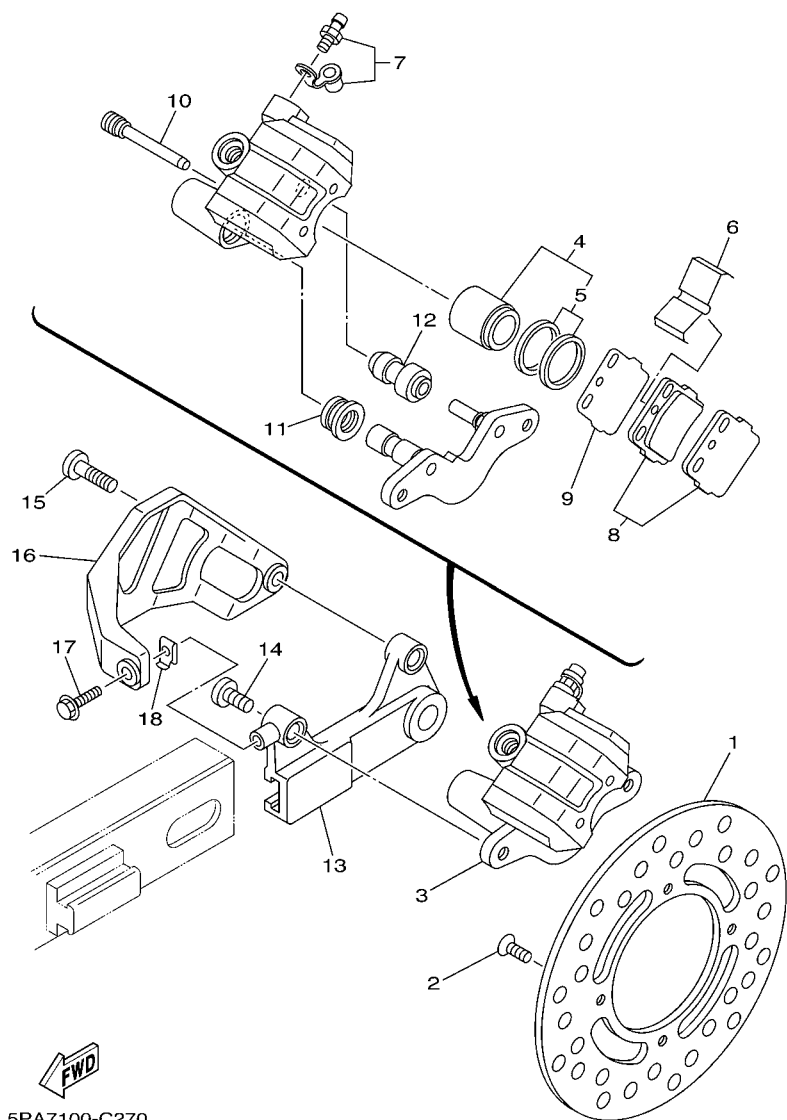

5PA7100-C270

REF. NO.	PART NO.	DESCRIPTION	9PAA	9PAC	5SHA	5SHC	REMARKS
1	5PA-2582W-00	DISK, REAR BRAKE 2	1	1	1	1	
2	90149-06327	SCREW	4	4	4	4	
3	5PA-2580W-00	CALIPER ASSY, REAR 2	1	1	1	1	
4	4EW-W0057-50	.PISTON ASSY, CALIPER	1	1	1	1	
5	4ES-W0047-00	..CALIPER SEAL KIT	1	1	1	1	
6	1UY-25919-51	..SUPPORT, PAD	1	1	1	1	
7	1UY-W0048-50	.BLEED SCREW KIT	1	1	1	1	
8	5PA-W0046-50	.BRAKE PAD KIT 2	1	1	1	1	
9	3GD-25827-00	.SHIM, CALIPER	1	1	1	1	
10	3GD-25933-00	.PIN, PAD	2	2	2	2	
11	1UY-25917-51	.BOOT, CALIPER	1	1	1	1	
12	1UY-25937-51	.BOOT 2	1	1	1	1	
13	4ES-25920-00	SUPT. BRKT. ASSY.	1	1	1	1	
14	90110-08096	BOLT, HEXAGON SOCKET HEAD	1	1	1	1	
15	90109-08718	BOLT	1	1	1	1	
16	4ES-27491-00	PROTECTOR	1	1	1	1	
17	95027-06012	BOLT, FLANGE	1	1	1	1	
18	4ES-27114-00	STOPPER, MAIN STAND	1	1	1	1	

FIG. 28 STEERING HANDLE & CABLE

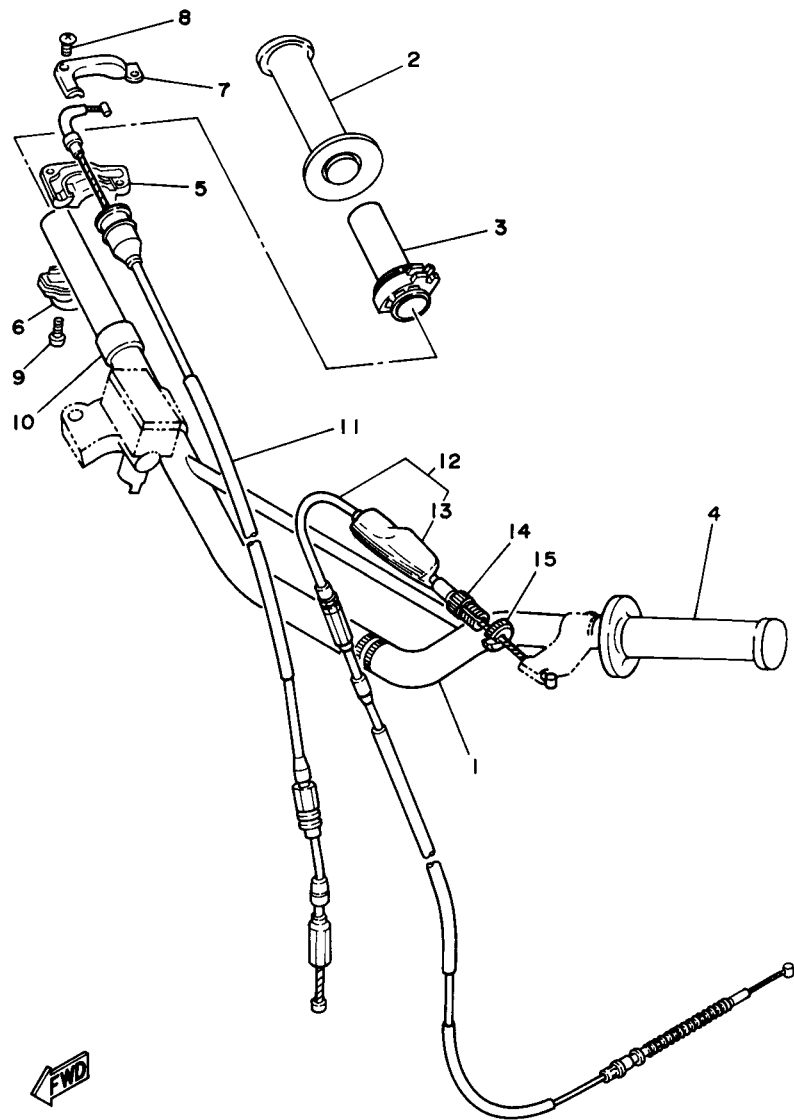

4ES6100-7280

REF. NO.	PART NO.	DESCRIPTION	5PAA	5PAC	5SHA	5SHC	REMARKS
1	5PA-26111-00	HANDLEBAR	1	1	1	1	
2	4GY-26242-00	GRIP (RIGHT)	1	1	1	1	
3	22W-26243-00	TUBE, THROTTLE GUIDE	1	1	1	1	
4	4GY-26241-00	GRIP	1	1	1	1	
5	5X2-26281-00	CAP, GRIP UPPER	1	1	1	1	
6	322-26282-00	CAP, GRIP LOWER	1	1	1	1	
7	5X2-2628H-01	CAP, WIRE	1	1	1	1	
8	98707-04012	SCREW, FLAT HEAD	2	2	2	2	
9	98507-05016	SCREW, PAN HEAD	2	2	2	2	
10	90387-227H7	COLLAR	1	1	1	1	
11	5PA-26311-00	CABLE, THROTTLE 1	1	1	1	1	
12	4ES-26335-11	CABLE, CLUTCH	1	1	1	1	
13	498-26372-00	.COVER, HANDLE LEVER 1	1	1	1	1	
14	90123-08046	BOLT	1	1	1	1	
15	90179-08148	NUT	1	1	1	1	

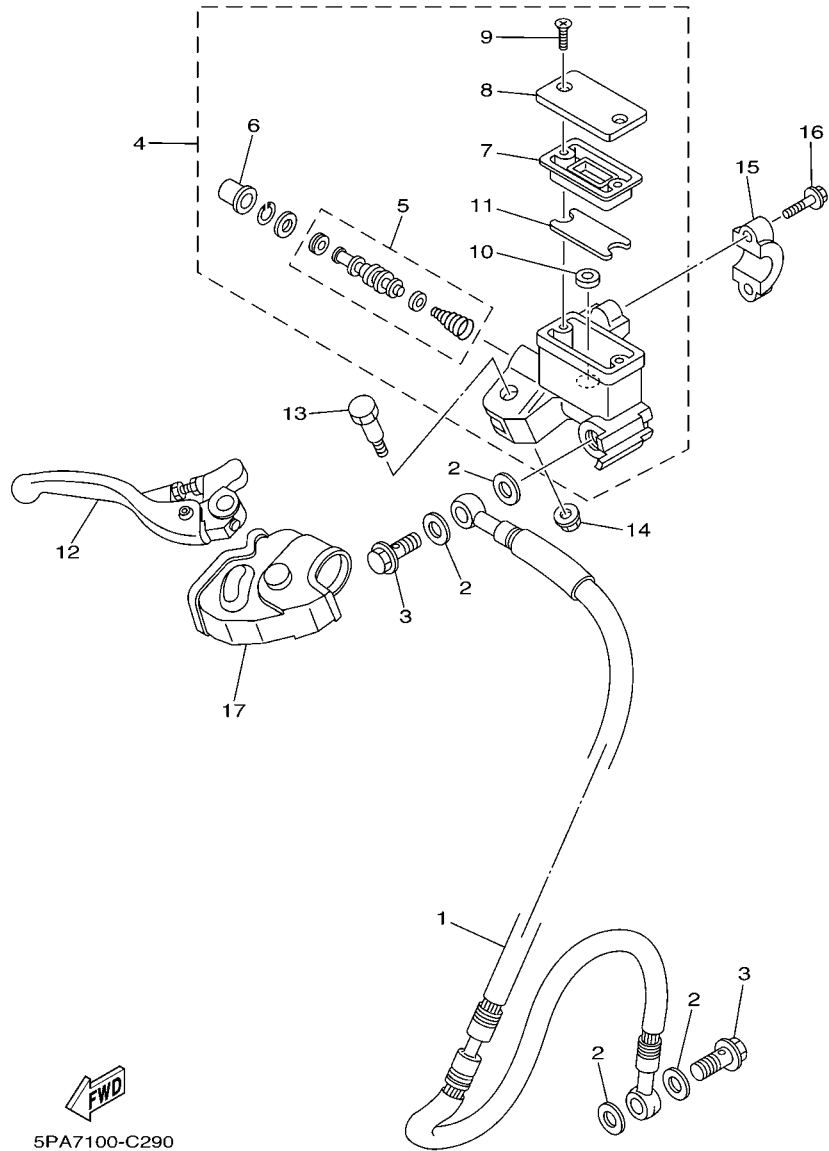

5PA7100-C290

FIG. 29 FRONT MASTER CYLINDER

REF. NO.	PART NO.	DESCRIPTION	5PAA	5PAC	5SHA	5SHC	REMARKS
1	4ES-25872-10	HOSE, BRAKE 1	1	1			
	5SH-25872-00	HOSE, BRAKE 1			1	1	
2	90201-10118	WASHER, PLATE	4	4	4	4	
3	90401-10168	BOLT, UNION	2	2	2	2	
4	5XE-W2587-00	MASTER CYLINDER SUB ASSY	1	1	1	1	
5	5NY-W0041-00	.CYLINDER KIT, MASTER	1	1	1	1	
6	5NY-25868-00	.BOOT, MASTER CYLINDER	1	1	1	1	
7	5XE-25854-00	.DIAPHRAGM, RESERVOIR	1	1	1	1	
8	5MV-25852-01	.CAP, RESERVOIR	1	1	1	1	
9	98706-04012	.SCREW, FLAT HEAD	2	2	2	2	
10	5CG-25715-00	.SEPARATOR ASSY	1	1	1	1	
11	5XE-25853-00	.FLOAT, RESERVOIR	1	1	1	1	
12	5MV-83922-00	LEVER 2	1	1	1	1	
13	5MV-2589F-00	BOLT, LEVER	1	1	1	1	
14	95701-06500	NUT, FLANGE	1	1	1	1	
15	5MV-25867-00	BRACKET, MASTER CYLINDER	1	1	1	1	
16	5MV-25833-00	BOLT, FITTING	2	2	2	2	
17	5NY-26372-00	COVER, HANDLE LEVER 1	1	1	1	1	

FIG. 30 STAND & FOOTREST

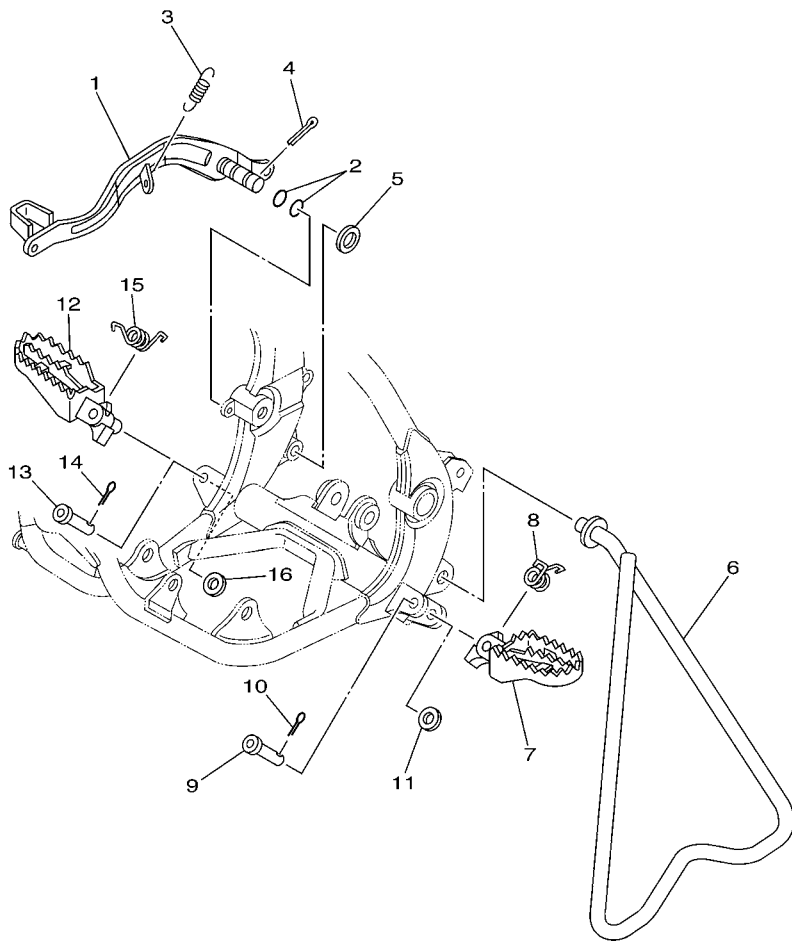

5PA1100-A300

REF. NO.	PART NO.	DESCRIPTION	5PAA	5PAC	5SHA	5SHC	REMARKS
1	5PA-27211-00	PEDAL, BRAKE	1	1	1	1	
2	93210-11073	O-RING	2	2	2	2	
3	90506-15480	SPRING, TENSION	1	1	1	1	
4	91401-20025	PIN, COTTER	1	1	1	1	
5	90201-15700	WASHER, PLATE	1	1	1	1	
6	5PA-27311-00	STAND, SIDE	1	1			
	5SH-27311-00	STAND, SIDE			1	1	
7	5ET-27411-00	FOOTREST 1	1	1	1	1	
8	90508-282B8	SPRING, TORSION	1	1	1	1	
9	90240-10142	PIN, CLEVIS	1	1	1	1	
10	91401-25015	PIN, COTTER	1	1	1	1	
11	90201-10119	WASHER, PLATE	1	1	1	1	
12	5ET-27421-00	FOOTREST 2	1	1	1	1	
13	90240-10142	PIN, CLEVIS	1	1	1	1	
14	91401-25015	PIN, COTTER	1	1	1	1	
15	90508-282B9	SPRING, TORSION	1	1	1	1	
16	90201-10119	WASHER, PLATE	1	1	1	1	

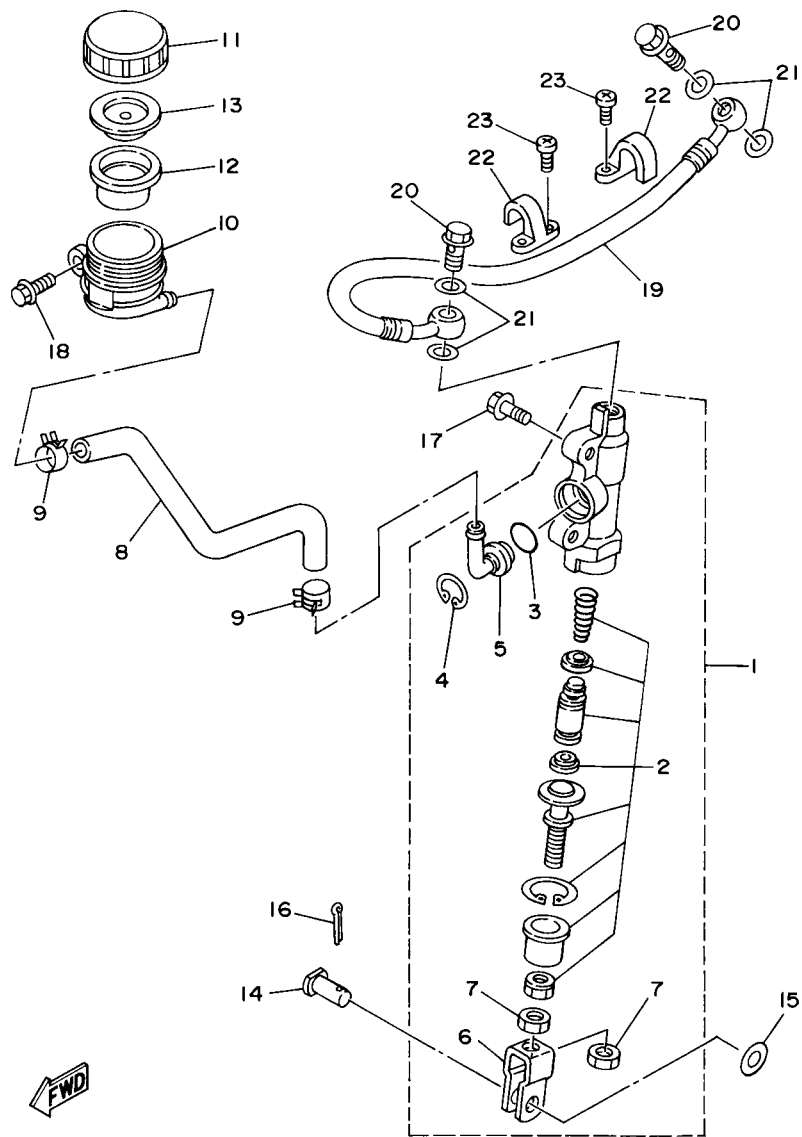

4ES1100-3310

FIG. 31 REAR MASTER CYLINDER

REF. NO.	PART NO.	DESCRIPTION	5PAA	5PAC	5SHA	5SHC	REMARKS
1	4ES-2583V-00	RR. MASTER CYLINDER ASSY.	1	1	1	1	
2	1FK-W0042-50	.CYLINDER KIT, MASTER	1	1	1	1	
3	93210-15620	.O-RING	1	1	1	1	
4	2VN-25866-00	.CIRCLIP	1	1	1	1	
5	2VN-2582A-50	.JOINT	1	1	1	1	
6	2YK-27222-00	.JOINT	1	1	1	1	
7	95307-08600	.NUT	2	2	2	2	
8	4ES-25895-00	HOSE, RESERVOIR	1	1	1	1	
9	90467-11044	CLIP	2	2	2	2	
10	4EW-25894-00	TANK, RESERVOIR	1	1	1	1	
11	3XP-25852-50	CAP, RESERVOIR	1	1	1	1	
12	2VN-25854-00	DIAPHRAGM, RESERVOIR	1	1	1	1	
13	2VN-25855-00	BUSH, DIAPHRAGM	1	1	1	1	
14	90240-08124	PIN, CLEVIS	1	1	1	1	
15	90201-08083	WASHER, PLATE	1	1	1	1	
16	91401-16012	PIN, COTTER	1	1	1	1	
17	95027-06016	BOLT, FLANGE	2	2	2	2	
18	95027-06012	BOLT, FLANGE	1	1	1	1	
19	5PA-25873-00	HOSE, BRAKE 2	1	1			
	5SH-25873-00	HOSE, BRAKE 2			1	1	
20	90401-10168	BOLT, UNION	2	2	2	2	
21	90201-10118	WASHER, PLATE	4	4	4	4	
22	2VM-25876-00	HOLDER, BRAKE HOSE 2	2	2	2	2	
23	98507-05010	SCREW, PAN HEAD	4	4	4	4	

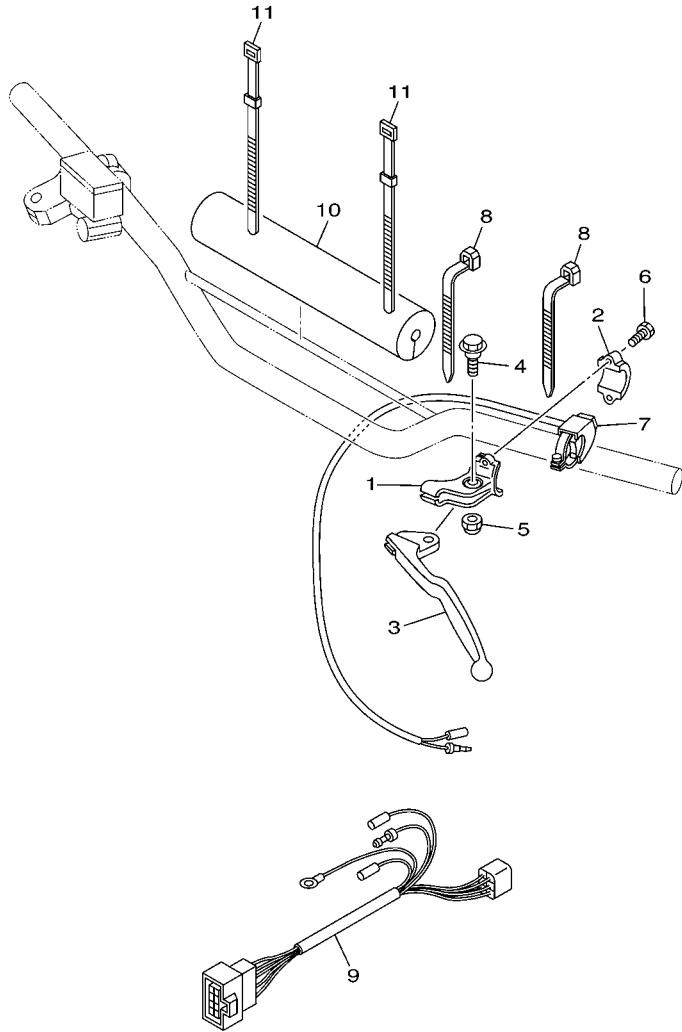

5PAA100-D330

FIG. 33 HANDLE SWITCH & LEVER

REF. NO.	PART NO.	DESCRIPTION	5PAA	5PAC	5SHA	5SHC	REMARKS
1	38V-82911-00	HOLDER, LEVER 1	1	1	1	1	
2	38V-82913-00	HOLDER, LEVER LOWER 1	1	1	1	1	
3	4GY-83912-00	LEVER 1	1	1	1	1	
4	90109-06799	BOLT	1	1	1	1	
5	95607-06100	NUT, U	1	1	1	1	
6	97007-05016	BOLT	2	2	2	2	
7	22W-83976-01	SWITCH, HANDLE 1	1	1	1	1	
8	90464-13077	CLAMP	2	2	2	2	
9	5PA-82509-00	WIRE, SUB LEAD	1	1	1	1	
10	2X1-26124-00	PROTECTOR, HANDLEBAR	1	1	1	1	
11	437-83936-11	BAND, SWITCH CORD	2	2	2	2	

D13

FIG. 34 ELECTRICAL 1

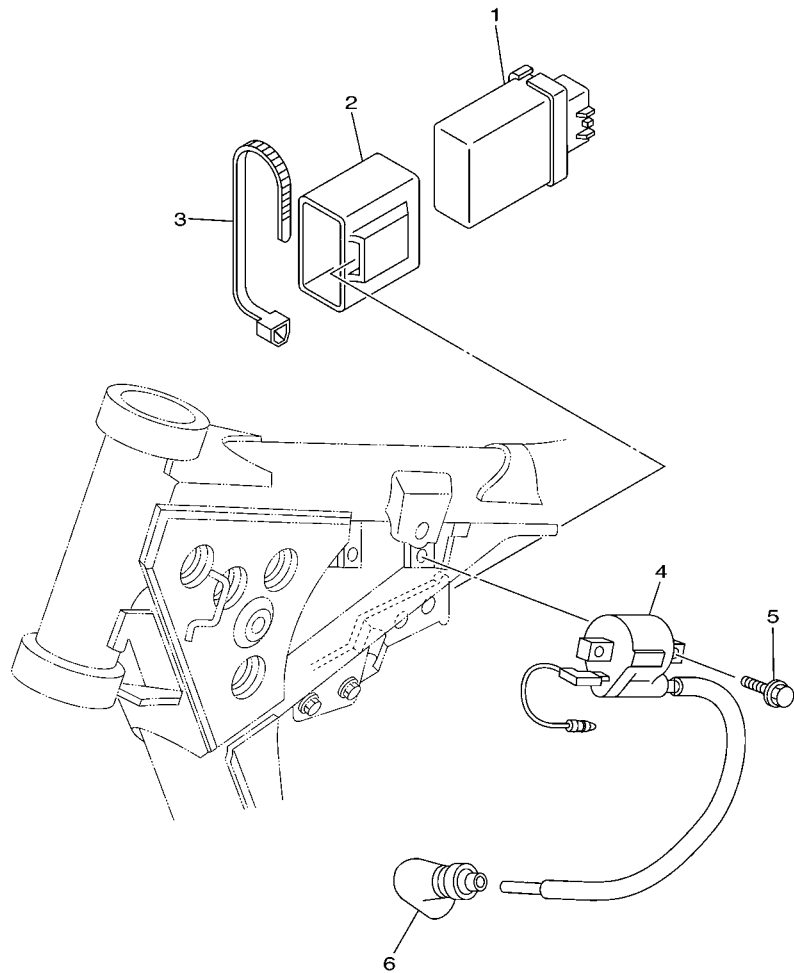

REF. NO.	PART NO.	DESCRIPTION	5PAA	5PAC	5SHA	5SHC	REMARKS
1	5PA-85540-00	C.D.I. UNIT ASSY	1	1	1	1	
2	5PA-85546-00	BAND	1	1	1	1	
3	90460-15126	CLAMP, HOSE	1	1	1	1	
4	5PA-82310-00	IGNITION COIL ASSY	1	1	1	1	
5	95027-06016	BOLT, FLANGE	2	2	2	2	
6	8DG-82370-00	PLUG CAP ASSY	1	1	1	1	

 5PA1100-A340

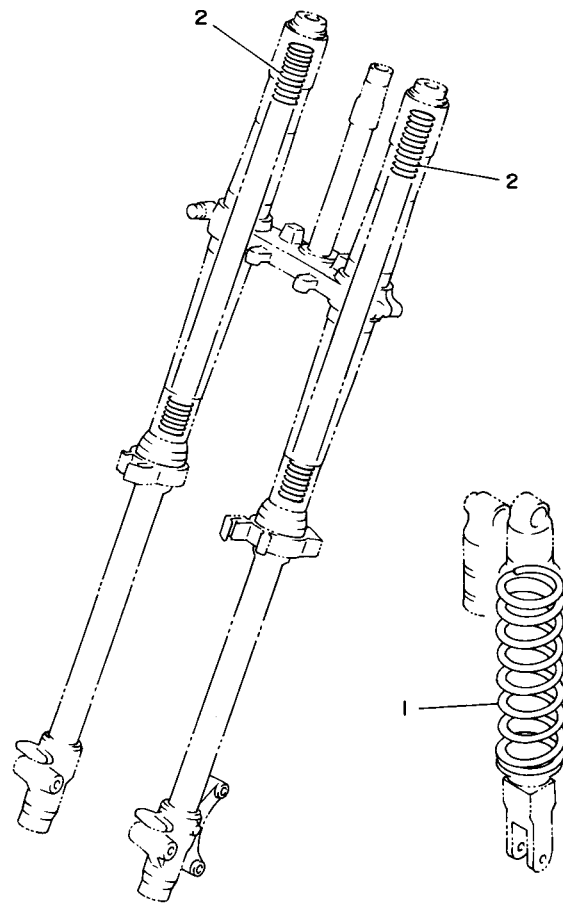

4ES1100-3350

FIG. 35 ALTERNATE FOR CHASSIS

REF. NO.	PART NO.	DESCRIPTION	5PAA	5PAC	5SHA	5SHC	REMARKS
1	4ES-22212-M0	SPRING (K=43N/MM)	1				AP
	4ES-22212-K0	SPRING (K=45N/MM)			1		AP
	4ES-22212-G0	SPRING (K=47N/MM)	1	1			AP
	4ES-22212-F0	SPRING (K=49N/MM)			1	1	AP
	4ES-22212-H0	SPRING (K=51N/MM)	1	1			AP
	4ES-22212-J0	SPRING (K=53N/MM)				1	AP
2	4ES-23141-50	SPRING, FRONT FORK(K=2.7N/MM)	2	2			AP
	4ES-23141-40	SPRING, FRONT FORK(K=2.8N/MM)			2	2	AP
	4ES-23141-60	SPRING, FRONT FORK(K=2.9N/MM)	2	2			AP
	4ES-23141-70	SPRING, FRONT FORK(K=3.0N/MM)			2	2	AP

NUMERICAL INDEX

PART NO.	GRID NO.	PART NO.	GRID NO.	PART NO.	GRID NO.	PART NO.	GRID NO.	PART NO.	GRID NO.	PART NO.	GRID NO.
5PA-11111-00	B - 2	5PA-14392-00	B - 7	5PA-15463-00	B - 11	4ES-2153E-01	C - 5	4ES-22214-00	C - 9	4ES-23485-00	C - 11
5PA-11311-00	B - 2	5PA-14411-00	B - 6	5PA-15620-00	B - 12	5PA-21611-00	C - 5	4ES-22216-00	C - 9	5PA-24110-11	C - 15
4ES-11351-00	B - 2	5PA-14417-00	B - 6	5PA-15621-00	B - 12	4ES-21642-00	C - 5	4ES-22251-00	C - 9	4EW-2412F-00	C - 15
5PA-11400-00	B - 3	5PA-14451-00	B - 6	5PA-15641-00	B - 12	5PA-21711-00	C - 6	5PA-22253-00	C - 8	24X-24144-00	C - 15
5PA-11412-00	B - 3	5PA-14453-00	B - 6	5PA-15651-00	B - 12	5PA-21721-00	C - 6	5PA-22475-00	C - 8	5PA-24181-00	C - 15
5PA-11422-00	B - 3	5PA-14458-00	B - 6	5PA-15660-00	B - 12	5PH-2172A-10	C - 6	5PA-23102-00	C - 12	5PA-24182-00	C - 15
5PA-11611-00	B - 3	5PA-14459-00	B - 6	4ES-15664-00	B - 12	5PA-21731-00	C - 6	5SH-23102-00	C - 12	5PA-24240-30	C - 15
	E - 2	4ES-14462-00	B - 6	5PA-16111-00	B - 13	5PA-2173E-10	C - 6	5PA-23103-00	C - 12	5PA-24244-30	C - 6
5PA-11630-00	E - 2	676-14548-00	B - 7	5PA-16150-10	B - 13	5PA-2173F-10	C - 6	5SH-23103-00	C - 12	5PA-24311-00	C - 15
5PA-11631-00-A0	B - 3	4MX-14561-00	B - 7	5PA-16181-00	B - 13	1FK-21746-00	C - 6	5PA-23110-00	C - 12	3XJ-24380-00	C - 15
5PA-11631-00-B0	B - 3	5PA-14610-00	B - 9	21V-16321-00	B - 13	5PA-22110-00	C - 7	4ES-23111-10	C - 12	4DP-24500-01	C - 15
	E - 2	17W-14615-00	B - 9	4ES-16321-00	B - 13	5SH-22110-10	C - 7	5PA-23120-00	C - 12	4X8-24512-00	C - 15
5PA-11631-00-C0	B - 3	5PA-14642-00	B - 9	131-16324-00	B - 13	5PA-22128-00	C - 7	5PA-23125-00	C - 12	3AC-24523-00	C - 15
5PA-11631-00-D0	B - 3	4ES-1469A-00	B - 9	2TK-16351-00	B - 13	4ES-22129-00	C - 7	3JD-2312G-L0	C - 12	3AJ-24534-01	C - 15
4ES-11633-00	B - 3	5PA-1469A-00	B - 9	4ES-16356-00	B - 13	5PA-22151-00	C - 7	5PA-23136-00	C - 12	5NY-24610-00	C - 15
	E - 2	5PA-14753-00	B - 9	5PA-16357-00	B - 13	5PA-22176-00	C - 8	4LB-23141-10	C - 12	5PA-2470F-00	D - 2
4ES-11650-10	E - 2	4ES-14753-20	B - 9	5PA-16371-10	B - 13	30X-22178-00	C - 4	4ES-23141-40	C - 12	5PA-24718-00	D - 2
4ES-11651-10	B - 3	565-14771-00	B - 9	4ES-16381-00	B - 13	4ES-22178-00	C - 4		D - 15	5PA-24728-00	D - 2
	E - 2	5PA-14916-KE	B - 7	4ES-17121-01	B - 14	5PA-2217A-00	C - 7	4ES-23141-50	D - 15	5PA-24770-10	D - 2
2RA-11681-00	B - 3	5PA-14916-KF	B - 7	4ES-17131-02	B - 14	4ES-2217F-00	C - 8	4ES-23141-60	D - 15	4LB-25104-00	D - 3
	E - 2	5PA-14916-KG	B - 7	4ES-17151-10	B - 14	4V4-22184-00	C - 4	4ES-23141-70	D - 15	4ES-25104-20	D - 3
4BA-12422-00	B - 4	5PA-14916-LE	B - 7	4ES-17161-10	B - 14	5PA-22184-00	C - 8	4ES-23142-00	C - 12	4ES-25111-00	D - 3
4BA-12428-00	B - 4	5PA-14916-LF	B - 7	4ES-17211-01	B - 14	5PA-22199-00	C - 7	4ES-23144-00	C - 12	4ES-25181-00	D - 3
5PA-12451-00	B - 4	5PA-14916-LG	B - 7	5PA-17221-00	B - 14	5PA-22201-00	C - 9	4ES-23145-00	C - 12	22W-25181-01	C - 7
5PA-12459-00	B - 4	4MX-14919-00	B - 7	4ES-17231-10	B - 14	5PA-22201-10	C - 9	5K5-23149-00	C - 12	4ES-25183-10	D - 3
5PA-12461-00	B - 5	5HC-14922-00	B - 8	5PA-17241-00	B - 14	5SH-22201-10	C - 9	5PA-23149-00	C - 12	1T1-25194-00	D - 3
5HD-12462-00	B - 5	5HC-14934-00	B - 8	4ES-17251-00	B - 14	5PA-22201-20	C - 9	4ES-2314F-00	C - 13	4LB-25304-00	D - 5
22W-12463-00	B - 5	4MX-14943-34	B - 8	5PA-17261-00	B - 14	5SH-22201-20	C - 9	5PA-2314H-L0	C - 13	4ES-25304-20	D - 5
4ES-12481-10	B - 5	4MX-14943-35	B - 8	5PA-17411-00	B - 14	5PA-22201-30	C - 9	5PA-2314J-L0	C - 13	4ES-25311-00	D - 5
5PA-12482-00	B - 5	4MX-14943-36	B - 8	5PA-17421-00	B - 14	5PA-22201-40	C - 9	4A1-23156-00	C - 12	4ES-25381-01	D - 6
353-13115-01	B - 10	4MX-14943-84	B - 8	164-17427-00-06	B - 14	5PA-22210-00	C - 9	2HH-23158-L0	C - 12	4ES-25383-00	D - 5
5PA-13565-00	B - 6	4MX-14943-85	B - 8	164-17427-00-08	B - 14	5PA-22210-10	C - 9	5PA-2316A-00	C - 12	4ES-25383-10	D - 6
4ES-13610-00	B - 6	4MX-14943-86	B - 8	164-17427-00-10	B - 14	5SH-22210-10	C - 9	5SH-2316A-00	C - 12	5PA-25388-00	D - 6
4ES-13613-00	B - 6	4MX-14943-87	B - 8	5PA-18101-00	C - 3	5PA-22210-20	C - 9	5PA-23170-00	C - 12	1T2-25394-00	D - 5
4ES-13616-00	B - 6	4MX-14948-04	B - 7	2HF-18110-01	C - 3	5SH-22210-20	C - 9	5PA-23171-00	C - 12	5X2-25394-00	D - 5
5PA-14101-00	B - 7	4MX-14948-05	B - 7	5PA-1811E-00	C - 3	5PA-22210-30	C - 9	58T-23184-L0	C - 9	5PA-25446-00	D - 5
5PA-14105-00	B - 7	4MX-14948-06	B - 7	5PA-18140-00	C - 3	5PA-22210-40	C - 9	4V4-23188-L0	C - 12	4ES-25447-20	D - 5
5PA-1410E-00	B - 7	5PA-14984-00	B - 7	4ES-18511-02	C - 2	4ES-22212-F0	C - 9	4V4-23194-L0	C - 13	5PA-25448-00	D - 5
4MX-14115-00	B - 7	5PA-14985-00	B - 7	5R2-18512-00	C - 2		D - 15	4ES-23318-00	C - 14	5PA-25449-00	D - 5
5PA-14126-00	B - 7	5PA-15111-00	B - 10	4ES-18513-01	C - 2	4ES-22212-G0	C - 9	5PA-2331E-00	C - 13	5PA-25451-00	D - 5
5PA-14131-00	B - 7	5PA-15118-00	B - 10	4BA-18531-00	C - 2		D - 15	5PA-23340-01	C - 13	5PA-25452-00	D - 5
3TJ-14137-40	B - 8	5PA-15121-10	B - 10	4BA-18535-00	C - 2	4ES-22212-H0	C - 9	5NY-23346-L0	C - 13	5PA-25453-00	D - 6
5PA-14146-00	B - 8	3Y1-15363-00	B - 11	4ES-18540-00	C - 2		D - 15	3XJ-23357-L0	C - 12	5CG-25715-00	D - 9
5PA-14159-00	B - 7	4ES-15411-00	B - 11	5PA-21101-11-P0	C - 4	4ES-22212-J0	D - 15	4DA-23389-00	C - 11	5PA-2580T-00	D - 4
4JT-14171-00	B - 7	5PA-15415-00	B - 11	5PA-21190-00-P0	C - 4	4ES-22212-K0	C - 9	3JD-23394-00	C - 12	5PA-2580W-00	D - 7
5PA-14194-00	B - 8	5PA-15431-00	B - 11	5PA-21274-00	C - 4		D - 15	1J7-23415-00	C - 11	3GD-25827-00	D - 7
4XL-14197-10	B - 7	5PA-15451-00	B - 11	4ES-21511-20	C - 5	4ES-22212-M0	D - 15	4ES-23435-00	C - 11	2VN-2582A-50	D - 11
5PA-14340-00	B - 7	4ES-15461-00	B - 11	4XL-2153A-10	C - 14	3JD-22214-00	C - 9	3SP-23441-00	C - 11	5PA-2582T-00	D - 4

NUMERICAL INDEX

PART NO.	GRID NO.	PART NO.	GRID NO.	PART NO.	GRID NO.	PART NO.	GRID NO.	PART NO.	GRID NO.	PART NO.	GRID NO.
5PA-2582W-00	D - 7	5ET-27411-00	D - 10	90119-06001	C - 6	90201-124F8	B - 12	90387-202A0	B - 15	93101-12173	C - 3
5MV-25833-00	D - 9	5ET-27421-00	D - 10	90119-06038	B - 5	90201-124G9	C - 7	90387-20488	B - 13	93101-17062	C - 8
4ES-2583V-00	D - 11	4ES-27491-00	D - 7	90119-06063	C - 5	90201-12749	C - 8	90387-227H7	D - 8	93102-12106	B - 4
5MV-25852-01	D - 9	5PA-82310-00	D - 14	90119-06118	C - 4	90201-127J6	C - 8	90401-10168	D - 9	93102-12224	B - 13
3XP-25852-50	D - 11	8DG-82370-00	D - 14	90119-06185	C - 5	90201-152L7	D - 6		D - 11	93102-17263	B - 12
5XE-25853-00	D - 9	5PA-82509-00	D - 13	90119-06190	C - 15	90201-15700	D - 10	90430-06166	B - 4	93102-20009	D - 5
2VN-25854-00	D - 11	38V-82911-00	D - 13	90119-06192	C - 5	90201-171G6	B - 13	90430-08119	B - 11	93102-20447	B - 3
5XE-25854-00	D - 9	38V-82913-00	D - 13	90119-06225	C - 6	90201-17545	B - 14	90445-08376	B - 10	93102-26042	B - 15
2VN-25855-00	D - 11	4GY-83912-00	D - 13	90122-06002	B - 6	90201-17558	B - 13	90445-09220	C - 15	93102-28009	B - 3
2VN-25866-00	D - 11	5MV-83922-00	D - 9	90123-08046	D - 8	90201-176L4	B - 12	90445-09300	C - 15	93106-20031	D - 3
5MV-25867-00	D - 9	437-83936-11	D - 13	90149-06011	C - 15	90201-177G4	C - 3	90450-25037	B - 5	93109-11073	B - 4
5NY-25868-00	D - 9	22W-83976-01	D - 13		D - 12	90201-20611	B - 14	90450-28014	B - 5	93109-17071	C - 7
5SH-25872-00	D - 9	5PA-85540-00	D - 14	90149-06327	D - 4	90201-220T0	C - 11	90450-99064	B - 6	93210-11073	D - 10
4ES-25872-10	D - 9	5PA-85546-00	D - 14		D - 7	90201-256K5	C - 11	90460-15126	D - 14	93210-26452	B - 12
5PA-25873-00	D - 11	4SS-85550-10	D - 12	90152-06010	B - 12	90201-33299	B - 9	90460-41191	B - 6	93210-15620	D - 11
5SH-25873-00	D - 11	5PA-85560-00	D - 12	90157-05079	C - 11	90202-05193	C - 15	90460-56105	B - 6	93210-19123	B - 11
2VM-25876-00	D - 11	5NY-W0041-00	D - 9	90157-06071	B - 14	90208-12015	B - 13	90461-10136	B - 10	93210-56459	B - 2
4EW-25894-00	D - 11	1FK-W0042-50	D - 11	90159-06078	C - 6	90209-06096	B - 6	90464-13077	B - 5	93210-84724	B - 2
4ES-25895-00	D - 11	5PA-W0045-00	D - 4	90159-06182	C - 6	90209-06187	C - 5		D - 12	93306-00105	B - 4
5MV-2589F-00	D - 9	5PA-W0046-50	D - 7	90176-08026	B - 2	90209-14008	B - 14	90465-13275	D - 13	93306-00203	D - 5
34X-25914-00	D - 4	4ES-W0047-00	D - 7	90179-08148	D - 8	90209-16209	B - 14	90467-08002	C - 15	93306-20120	D - 3
1UY-25917-51	D - 7	4ES-W0047-10	D - 4	90179-08299	B - 2	90209-20159	B - 3	90467-09002	B - 5	93306-20203	D - 5
56A-25919-00	D - 4	51L-W0048-00	D - 4	90179-12659	B - 13		E - 2	90467-09002	C - 15	93306-20333	B - 14
56A-25919-10	D - 4	1UY-W0048-50	D - 7	90179-16226	B - 15	90215-20261	B - 15	90467-10008	C - 15	93306-20401	B - 15
1UY-25919-51	D - 7	4ES-W0057-10	D - 4	90179-22412	C - 11	90240-08124	D - 11	90467-11044	D - 11	93306-20438	B - 3
4ES-25920-00	D - 7	4EW-W0057-50	D - 7	90179-25033	C - 11	90240-10142	D - 10	90468-23194	B - 12	93306-30421	B - 3
56A-25926-00	D - 4	5XE-W2587-00	D - 9	90183-06023	C - 5	90250-06013	C - 2	90480-15528	B - 5	93310-21417	B - 3
3GD-25933-00	D - 7	90101-08475	D - 6	90185-08169	D - 6	90267-48138	B - 6	90480-16561	B - 9		E - 2
56A-25937-00	D - 4	90101-12755	C - 8	90185-10110	C - 9	90280-03017	B - 3	90480-18411	B - 9	93310-420B1	B - 3
5R2-25937-00	D - 4	90105-08050	B - 10	90185-12046	D - 3	90282-05001	B - 13	90480-18549	C - 15		E - 2
1UY-25937-51	D - 7	90105-08211	D - 4	90185-12119	C - 8	90336-06031	B - 12	90501-12081	B - 12	93315-11206	B - 13
5PA-26111-00	D - 8	90105-10110	C - 4	90185-14142	D - 6	90338-10150	C - 8	90501-204A0	B - 13	93315-21455	C - 7
2X1-26124-00	D - 13	90105-10111	C - 4	90201-043H7	B - 6	90380-10218	C - 7	90506-15480	D - 10	93315-31502	B - 14
4GY-26241-00	D - 8	90105-10582	C - 7	90201-06050	B - 9	90380-12219	C - 8	90507-20052	B - 9	93317-11245	B - 14
4GY-26242-00	D - 8	90105-10614	C - 9	90201-06060	B - 12	90381-12091	C - 8	90508-14016	B - 13	93317-21746	C - 7
22W-26243-00	D - 8	90105-12382	C - 8		B - 14	90385-17042	C - 7	90508-24007	C - 3	93317-31771	C - 7
5X2-26281-00	D - 8	90109-065F3	B - 6	90201-060A3	B - 9	90387-06027	C - 15	90508-26750	B - 12	93332-00079	C - 11
322-26282-00	D - 8	90109-06799	D - 13	90201-08083	D - 11	90387-0614M	B - 5	90508-282B8	D - 10	93410-20038	B - 14
5X2-2628H-01	D - 8	90109-081G2	D - 6	90201-080L8	B - 2	90387-062X0	C - 7	90508-282B9	D - 10	93440-07182	B - 4
5PA-26311-00	D - 8	90109-08718	D - 7	90201-081R9	C - 4	90387-063G3	B - 9	90508-32016	C - 3	93440-15012	B - 14
4ES-26335-11	D - 8	90109-10729	C - 9	90201-08512	B - 4	90387-064X4	C - 5	91401-16012	D - 11	93440-17064	B - 14
498-26372-00	D - 8	90110-08096	C - 4	90201-086P8	D - 6	90387-067K6	C - 4	91401-20025	D - 10	93450-16115	B - 3
5NY-26372-00	D - 9		D - 7	90201-10118	D - 9	90387-0701A	C - 5	91401-25015	D - 10		E - 2
4ES-27114-00	D - 7	90116-08318	B - 2		D - 11	90387-105L0	B - 9	92017-06010	B - 9	93503-16003	B - 13
5PA-27211-00	D - 10	90116-08388	B - 2	90201-10119	D - 10	90387-1200U	C - 7	92017-06040	C - 7	93507-32009	B - 12
2YK-27222-00	D - 11	90116-08394	B - 2	90201-10591	D - 12	90387-124H0	D - 3	92903-04600	B - 7	9382A-14227	B - 15
5PA-27311-00	D - 10	90119-05001	B - 13	90201-112U6	C - 10	90387-127J7	C - 7	92907-03100	B - 6	9382A-15228	B - 15
5SH-27311-00	D - 10	90119-06001	B - 9	90201-12362	D - 3	90387-127J8	C - 7	92907-10600	C - 9	94107-17009	D - 3

NUMERICAL INDEX

PART NO.	GRID NO.	PART NO.	GRID NO.	PART NO.	GRID NO.	PART NO.	GRID NO.	PART NO.	GRID NO.	PART NO.	GRID NO.
94107-17011	D - 3	95607-06100	D - 13								
94107-19009	D - 3	95607-06200	C - 7								
94107-19011	D - 3	95607-08200	C - 7								
94109-14009	D - 5	95607-10200	C - 4								
94109-14011	D - 5		C - 7								
94109-16009	D - 5	95607-12200	C - 8								
94109-16011	D - 5	95617-12100	C - 7								
94207-17284	D - 3	95701-06500	D - 9								
94207-19290	D - 3	95807-08035	C - 11								
94208-14285	D - 5	95817-08125	C - 4								
94209-16291	D - 5	95827-06010	B - 5								
94307-16171	D - 5	95827-06060	B - 4								
94307-17166	D - 3	97007-05016	D - 13								
94307-19170	D - 3	97027-06020	C - 3								
94308-14165	D - 5	98504-04012	B - 8								
94414-17530	D - 3	98504-04014	B - 7								
94414-19521	D - 3	98507-03008	B - 6								
94416-14529	D - 5		C - 15								
94418-16522	D - 5	98507-05010	D - 11								
94682-00001	D - 6	98507-05016	D - 8								
94702-00368	B - 2	98507-06030	B - 11								
94709-00368	B - 2	98507-06040	B - 10								
95024-06010	C - 13	98507-06050	B - 10								
95027-06012	B - 12	98507-06060	B - 10								
	C - 4	98507-06070	B - 10								
	C - 11	98706-04012	D - 9								
	D - 2	98707-04012	D - 8								
	D - 7	98707-06025	C - 15								
	D - 11	99009-10400	C - 2								
95027-06014	C - 7	99009-12400	B - 12								
95027-06016	C - 14	99009-17400	C - 3								
	C - 15	99009-35500	D - 5								
	D - 11	99244-00140	C - 8								
	D - 14	99530-08016	B - 11								
95027-06020	B - 6	99530-10014	B - 10								
95027-06025	B - 4		B - 11								
	B - 9	99590-10114	B - 2								
	B - 11	9Y582-00117	D - 6								
95027-06030	B - 11	9Y582-00123	D - 6								
95027-06035	B - 11										
95027-06040	B - 11										
95027-08012	C - 4										
95027-08030	C - 11										
95027-08050	C - 7										
95027-08080	B - 11										
95307-08600	D - 11										
95307-08700	D - 6										
95317-10600	D - 12										